

Backplanes

AdvancedTCA
Switched Fabric Architectures
CompactPCI
PXI
VME
VME64x
VXI

Enclosures &
Components

Backplanes

System
Platforms

Cabinets

Switches,
Knobs & LEDs

ELMA
Your Solution Partner

Products & Services

ELMA ELECTRONIC



Switzerland



United States



Germany



France



United Kingdom



Israel



China



Romania

Elma is a global manufacturer of products for housing electronic systems. The company provides everything from components such as modular enclosures, cabinets and backplanes up to complete standard or custom system platforms. Elma also manufactures precision rotary switches. The company offers fast, flexible response to customer needs and extensive practical knowledge in tailoring solutions to specific applications.

Founded in 1960, Elma is an industry innovator in the design and manufacture of electronic enclosures and passive electronic components. Elma enjoys a leading position in the VME/VME64x, VXI, VXS, PXI, cPCI, ATCA and Rugged COTS packaging markets. Elma's component products consist of switches, knobs, and LED arrays. Headquartered in Switzerland, with partners in 22 countries, Elma has the ability to respond rapidly, with superior solutions to the requirements of its customers. Elma has a broad base of customers in diverse industries such as telecommunications, industrial control, medical electronics, military and defense.

Elma strives to provide products superior in quality, reliability, performance, and consistently presents new, innovative designs to the market. Elma's product line encompasses well over 16.000 parts, including enclosures, cabinets, high quality switches, LED arrays, knobs and much more. Elma also offers design and integration services backed by responsive and knowledgeable technical support.

Elma's leading quality level is achieved by expert training all employees and following systematic procedures based on ISO 9001 standards for which Elma is registered.

WHY CHOOSE ELMA?

Flexibility

Elma tailors solutions to individual applications to ensure fast and cost-effective results.

Experience

Extensive practical experience in packaging electronic systems is used to minimize the development time for new customized solutions without compromising system performance or reliability.

Compatibility

Because the two key electromechanical components - enclosures and backplanes - are made in-house, Elma guarantees compatibility, consistency and reliability.

Global Resources

With manufacturing operations in Europe, Asia and the USA, customers benefit from local service backed by global resources.

CUSTOM SOLUTIONS



Elma offers a wide range of services to assist our customers with new product introduction (NPI). From custom design and verification testing through agency certification, Elma has the experience to function as an extension of your company's design and compliance engineering team. Combined with Elma's level 4/5 integration capability for both embedded systems and switches, Elma provides a single solution to your outsourcing needs. Allow Elma to take your latest product from prototype to production quickly, cost effectively and with reduced risk.

COSTUMER PRODUCTS

Customization is the standard at Elma. With an extensive offering of modular products as a foundation, Elma is able to leverage existing solutions and proven design concepts to meet any custom application. This approach ensures that Elma will provide quality, compliant solutions with significantly reduced lead time, cost and risk.



Custom Enclosures & Components

- Modified standards for ATCA, cPCI, VME/VME64x systems
- IP protection classes
- EMC security



Custom Backplanes

- Modified standards for ATCA, cPCI, VXS VME/VME64x, VXI, PXI, and Switched Fabric
- NSC (non standard-based custom) design
- High-speed LVDS design
- Simulation/Backplane characterization
 - HSPICE, S-Parameters



Custom System Platforms

- VME/VME64x, cPCI, ATCA and Rugged
- Design to specification
- 20+ years design experience
- NEBS, ETSI



Custom Switches, Knobs & LEDs

- Modifiable Switches & LEDs
- Integration of Switches, Panels and other Components
- Custom Switch Bracket Fabrication

TECHNICAL CAPABILITIES

Elma uses the most advanced software and testing equipment to ensure our products comply with military and commercial standards. Elma has the capability to perform environmental testing, thermal testing and EMC testing to meet the desired specifications.



Agency Certification

- UL, CSA, CE
- FCC Class A, B
- CE
- NEBS

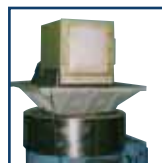

Verification Testing

- Environmental per MIL STD 810D
- Shock/Vibration Facilities



EMC Testing

- MIL STD 461
- FCC Class A, B
- CE
- NEBS

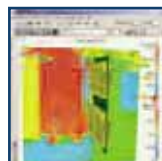

Thermal Testing

- Flotherm Simulation
- Load card testing
- CFM/LFM Verification

Capabilities Backplanes

PRODUCTION

By providing in-house design, manufacturing, assembly and testing we provide "full service" for all packaging solutions.



Automatic Assembly Line

Max. PCB size: 800 x 600 mm

Max. PCB thickness: 8 mm

Quantity targets: 25 to 25.000 pcs/a

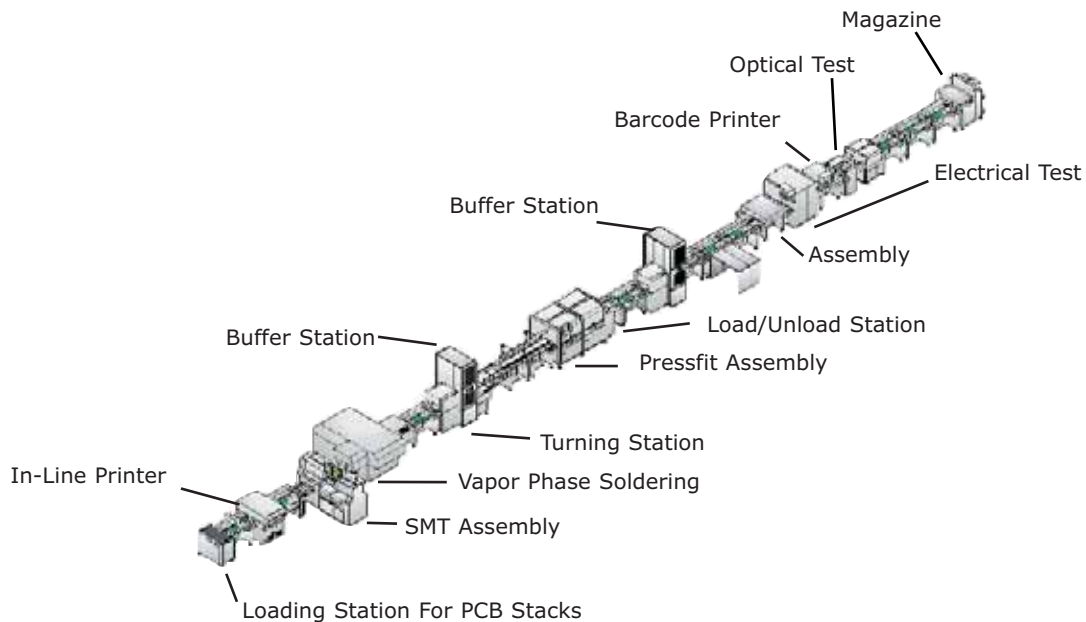

Elma offers an extensive line of backplanes and accessories to meet the requirements of the embedded systems market. These backplanes are produced using the latest in backplane design and manufacturing technology to insure the highest level of performance and quality in the industry.

In addition to the standard backplane products we can also offer a wide range of development backplanes and accessories. These backplanes could include power and ground only, full bus and no bus configurations. Accessories include form factor adapters, extender boards, load cards, and slot by pass cards.

Our design engineers use the most current technology in CAD tools and simulation to design custom and standard products. As a result, Elma backplanes are optimized for reliable and failure proof operation.

In-Line Printer

Two CCD-Cameras to control soldering paste printing and avoid shortcuts; Stencil cleaner



SMT Assembly

Capacity: 10.000 components/h
Precision: 0.03 mm
Location controlled by CCD camera



Vapor Phase Soldering

Infrared pre-heating
Vapour phase pre-heating

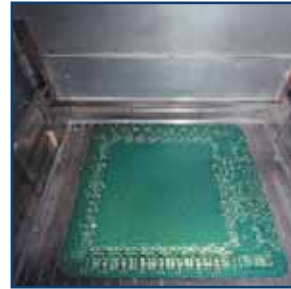

Pressfit Assembly

Cycle time: 3-5 sec
Precision: 0.2 mm
Measuring and control of force



Electrical Test

Test points: 21.620
Speed: 1.000 measurements/sec
Isolation, short circuit and continuity



Optical Test

Camera head: CCD matrix
Min. size: type 0805
Faults to be detected: missing, displaced, twisted and incorrectly polarized components



Capabilities Backplanes

ABOUT

Elma is the leader in high-performance backplane solutions. Our standard product portfolio includes VME/VME64x, cPCI, VXI, PXI, VXS, ATCA, and Switched Fabrics. Our application engineers also develop custom backplanes to meet your specifications, from initial concept to finished product.

System Accessories are also an important part of the Elma product portfolio. These include creative and innovative designs for cPCI-Bridges, test extender boards, voltage/system monitors, load boards and more.



PRODUCTS

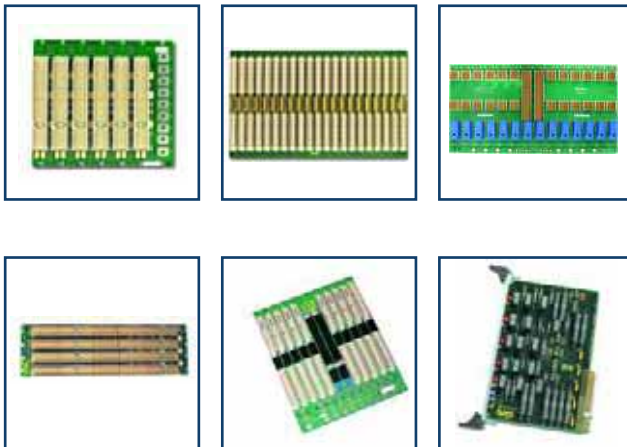

- cPCI
- ATCA
- Switched Fabrics
- VME/VME64x
- VME320
- VXS
- VXI
- PXI
- Accessories
- Custom Solutions

APPLICATIONS

- Aerospace
- Military/Homeland Security
- Industrial Automation
- Transportation
- Telecommunications
- Medical
- High-performance Computers



COSTUM

Since switched serial interconnects place higher performance demands on backplanes, you need a design team that is up to the challenge. Elma's backplane divisions – Elma Bustronic and Elma TreNew – are leaders and innovators in high-speed custom backplane design. Our signal integrity analysis and simulation/characterization tools (HSPICE, IConnect, etc.) ensure that we can supply you with an efficient cost-effective design solution that works perfectly the first time, every time.

And we continue to expand our technical resources with new high-speed measurement technology, interconnect model extraction, and software to support measurement driven design.

Table of contents

Products & Services	Page	2
Capabilities Backplanes	Page	4
PICMG 3.0 AdvancedTCA	Page	8
PICMG 2.5x Telecommunications Computing Architecture	Page	9
PICMG 2.16 CompactPCI Packet Switching Backplane	Page	10
CompactPCI 3U	Page	12
CompactPCI 6U	Page	14
cPCI Backplane with H.110 bus	Page	16
cPCI Backplane with Bridge	Page	18
PXI 3U	Page	20
cPCI Extenderboard	Page	22
CompactPCI Power Options	Page	24
CompactPCI Accessories	Page	25
VITA 41 VXS	Page	26
VITA 31.1 Gigabit Ethernet on VME64x	Page	27
VMEbus J1 <i>Classic</i>	Page	28
VMEbus J2 <i>Classic</i>	Page	30
VMEbus Monolithic <i>Classic</i>	Page	32
VME64x 6U	Page	34
VME64x 7U	Page	36
VME64x Extenderboard	Page	38
VXIbus Size C	Page	40
Available Options for VME <i>Classic</i> and VME64x Backplanes	Page	42
Accessories	Page	46
Overview of Elma Catalogs	Page	47

PICMG 3.0 AdvancedTCA

FEATURES

- Compliant with PICMG 3.0 Rev. 1.0 specification
- Dual Star, Dual-Dual Star or Full-Mesh topologies available
- Gigabyte/Terabyte per second bandwidth per shelf
- Connections to IPM Sentry shelf manager
- Pluggable shelf manager option
- Signal integrity characterization confirms high performance
- Eight differential pairs per channel
- Up to 10 Gbps per channel (verified during signal integrity testing)



AdvancedTCA®

ORDER CODE

020-937 5-slot with full mesh topology

018-221 14-slot with dual star topology

023-247 14-slot with dual-dual star topology

023-020 14-slot with full mesh topology

022-581 16-slot with full mesh topology

ABOUT AdvancedTCA

AdvancedTCA is the brand name for the PICMG 3.x series of specifications for next-generation central office and telecom application.

The PICMG 3.0 specification is the base specification that defines fabric protocols such as:

PICMG 3.1 for 10/100/1000 Ethernet

PICMG 3.2 for InfiniBand

PICMG 3.3 for StarFabric technologies

PICMG 3.4 for AdvancedTCA PCI Express

PICMG 3.5 for RapidIO

The PICMG 3.0 specification defines open architecture modular computing components that can be quickly integrated to deploy high performance services solutions.

The PICMG 3.0 architecture:

- Enables reduced development time and costs
- Provides multi-protocol support for interfaces up to 40 Gbps
- Offers high levels of modularity and configurability
- Improves power distribution and management
- Provides high levels of service availability 99.999 %
- Supports appropriate scalability of system performance and capacity

PICMG 2.5X Telecommunications Computing Architecture

FEATURES

- Compliant with
 - PICMG 2.5x D0.7 CompactTCA Specification
- 21 slots / 6U
- 2x slot locations for 3U Shelf Manager Cards
- 2x 2.16 Fabric Slots, right justified
- 14x 2.51 Slots: 1Gbps Packet Switching Links in P3, TDM bus in P4
- PICMG 2.9 IPMB bus to all slots
- Management and Power in P1/P2 area
- Radial control signals routed to the Shelf Manager Cards
- Power Input for standard voltages via up to 4 Positronic power supplies
- M3 bolts used for telecom voltages
- Control signals for up to 12 fans and for temperature sensors
- To be used with Elma Shelf Manager

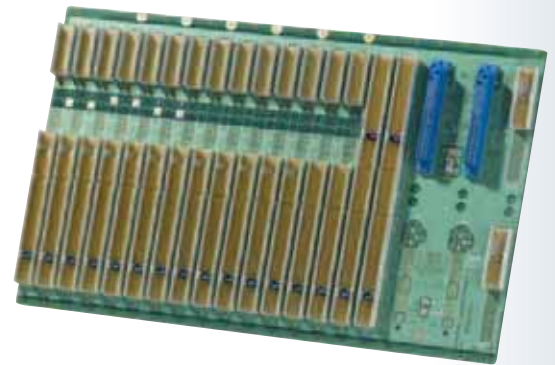

CompactTCA®

ORDER CODE

021-766

ABOUT PICMG 2.50 CompactTCA

The CompactTCA specification is intended to address the specific needs of the telecom market.

It will allow the evolution of CompactPCI products into an architecture that can serve parts of the telecom market that are cost or size constrained, where AdvancedTCA is not the best fit.

CompactTCA system platforms can support the portability and scalability of telecommunication applications, as well as other application classes between this new platform and PICMG 3.0 compliant AdvancedTCA systems.

The goal is to reduce optional features, leveraging CompactPCI equipment and provide a high degree of synergy with the AdvancedTCA platform management features. PICMG 2.50 offers reverse compatibility with existing PICMG 2.16 board level products that have system management but do not require the use of PCI bus.

Platforms may have one or two base hub slots and up to 24 node slots, as the application requires.

PICMG 2.16 CompactPCI Packet Switching Backplane

FEATURES

- Compliant with
 - PICMG 2.0 R3.0 CPCI Core Specification
 - PICMG 2.1 R2.0 Hot Swap Specification
 - PICMG 2.9 R1.0 System Management Specification
 - PICMG 2.16 R1.0 CPCI Packet Switching Backplane Spec.
- cPCI System Slot right (P1/P2 area; 64 bit/33 MHz)
- 1x Fabric Slot left
- 1000 Mbps differential pairs connected to node slots (P3)
- Modular power system (4 slot only)
 - ATX cable
 - M3 power bolts
 - Positronic PCI H47
 - DIN 41612 type M
- Shrouds: P3 to P5
- 10-layer controlled impedance strip-line design
- V(I/O) voltage configurable (connected by default to +5 V)
- Fastons for supplying HDD and fans
- Hot swap capability
- PCB height 262.05 mm
- PCB thickness 4.6 mm



016-299, 21-slot PICMG 2.16 cPSB Development Backplane

ORDER CODE

809 6 5 - 0 - 6 0 0

option	code and description	note
System Slot	6 - right side	
Fabric Slot	5 - left side	Gigabit Ethernet
Clock frequency	0 - 33 MHz, V(I/O) +5 V	
Number of slots	04, 06, 08	
Bridge	6 - without bridge	
Power connection	8 - Power bolts	4-8 slot
	9 - DIN 41612 Type M connector	4 slot
	H - ATX cable	4 slot
	J - Positronic PCI H47	4 slot
Bus width	0 - 64 bit	
Contact plating	0 - Power inputs tinned IEC pins gold-plated class 2	

GENERAL

PARAMETERS

About PICMG 2.16

The CompactPCI Packet Switching Backplane (cPSB) is an extension to the PICMG 2.x family of specifications that overlays a packet-based switching architecture on top of CompactPCI to create an Embedded System Area Network (ESAN). It supplements the robust, reliable and hot-swap capable CompactPCI architecture with the easily integrated, low-cost, high-performance and extensible Ethernet. This creates a platform well suited to the integration of components for the most demanding systems and empowers system integration and design to ascend to higher layers of the Open Systems Interconnection (OSI) protocol stack, thus reducing system integration time. A Packet Switching Backplane is composed of Node Slots, Fabric Slots, and the Links that interconnect them. The PSB topology is a star (not a bus). Each line interconnecting a Node Slot and Fabric Slot represents a Link that is a 10/100/1000 Mbps full-duplex Ethernet connection. Node Boards communicate by transferring/receiving packets to/from the Fabric Board, which transfers the packet to/from one or more Node Boards. Thus, every Node Board can communicate with every other Node Board and form a fabric.

Pinout 12-way header (FCON):

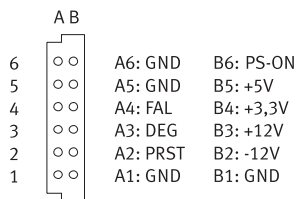

CLIMATIC

- Operating temperature -40 °C up to +85 °C
- Storage temperature -55 °C up to +85 °C
- Climatic conditions category to IEC 68/1: 25/085/21

MECHANICAL

- Flammability:
 - PCB: UL 94 V-0
 - Connectors: UL 94 V-0/-1
- Vibration:
 - According to DIN 41640 part 15: 10 Hz to 500 Hz 5 g rms
 - Impact (10 impacts per axis x,y,z) 50 g, 6 ms
- Layerstackup 10 layers/8 layers (2 Slot)
- Connector: 2 mm pitch, 7 rows,
 - Quality class 2 compliant to spec. IEC 61076-4-101 and BELLCORE GR-1217-CORE
 - Insertion force 0.75 N and extraction force 0.15 N of every contact

ELECTRICAL

- According to PICMG 2.0 R.3.0
- VI/O configurable to +3.3 V or +5 V (+5 V factory settings)
- Clock frequency: 33 MHz or 66 MHz (2-5 Slot)
- Bus width: 32/64 bit
- Data transfer rate:
 - cPCI: max. 533 Mbyte/s (66 MHz/64 bit)
 - Ethernet: 10/100/1000 Mbyte/s
- Impedance Z0 without connectors and daughter cards:
 - cPCI 65 Ohm +/-10 %
 - Ethernet 100 Ohm +/-10 %
- Termination with Schottky Diode Array: only optional for 8 slot with rear card
- Current carrying capacity of power planes
 - +3.3 V/GND: 10 A/slot
 - +5 V/GND: 8 A/slot
- Max. voltage drop (center to boardout): 20 mV

AVAILABLE SLOTS

No. of slot	4	6	8
PCB width (mm)	80.3	120.92	161.56

CompactPCI 3U

FEATURES

- Compliant with
 - PICMG 2.0 R3.0 CPCI Core Specification
 - PICMG 2.1 R2.0 Hot Swap Specification
 - PICMG 2.9 R1.0 System Management Specification
- System slot right or left
- Modular power system
 - 2 to 3 slot powered via:
 - Fastons
 - ATX cable
 - 4 to 8 slot powered via:
 - ATX cable
 - M3 power bolts (cable lugs, washer and nuts enclosed)
 - Positronic PCI H47 (pass through contacts enclosed)
 - DIN 41612 type M (pass through contacts enclosed)
- Shrouds: P2 (only for 32 bit Backplanes)
- 2 slot 8-layer construction; 3-8 slot 10-layer construction
- Number of slots: 2-8
- 10-21 slot available with cPCI to cPCI Bridge
- Virtually zero crosstalk
- Fastons for supplying HDD and fans
- Decoupling of the DC voltages far beyond 1 GHz (act as EMI-filter)
- Hot swap capability
- PCB height 128.7 mm
- PCB thickness 3.2 mm
- Connector for status signals "FCON"
 - Part number of mating connector including 1.0 m cable, open end: 008-083
- Service life (MTBF according to MIL-HDBK 217F):
 - 4 Slot 930.000 h
 - 8 Slot 470.000 h

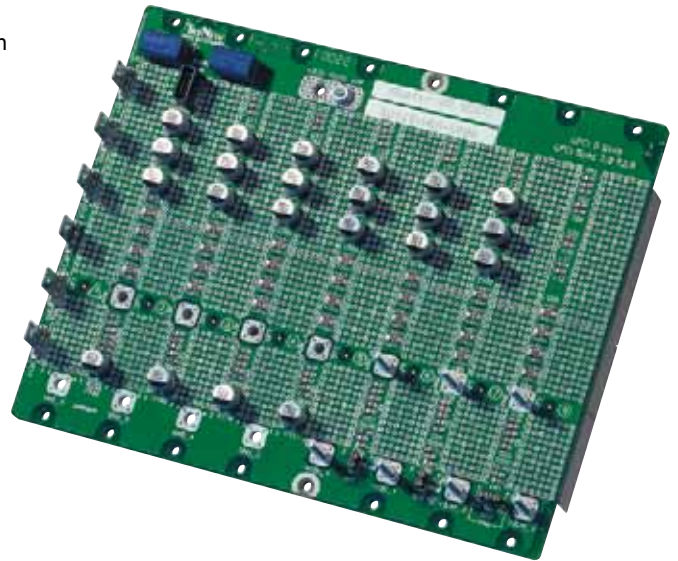

ORDER CODE

809 2 - - 6 0

option	code and description	note
System Slot	3 - left side 4 - right side	
Clock frequency	0 - 33 MHz, V(I/O) +5 V 6 - 66 MHz, V(I/O) +3.3 V	2-5 slot
Number of slots	02 to 08	
Bridge	6 - without bridge	
Power connection	6 - Fastons 8 - Power bolts 9 - DIN 41612 Type M connector H - ATX cable K - Positronic PCI H47	2-3 slot 4-8 slot 4-8 slot 2-8 slot 4-8 slot
Bus width	0 - 64 bit 1 - 32 bit	on request
Contact plating	0 - Power inputs tinned IEC pins gold-plated class 2	

GENERAL

CompactPCI (CPCI) is the specification for an industrial computer bus developed by PCI Industrial Computer Manufacturers Group (PICMG). CPCI is an adaptation of the Peripheral Component Interconnect (PCI) for industrial and/or embedded applications that require a more robust mechanical form factor than Desktop PCI.

Elma offers backplanes for operation at 33MHz with 2-8 slots. Backplanes with 2-5 slots are available for 66 MHz bus frequency. All Elma backplanes have 64-bit routing and are hot swap capable.

Connectors

The connector includes the following features:

- Coding mechanism and guiding device for rear cards
- Pin staging for hot swap
- Shrouds for rear I/O
- Shielding for EMI/RFI protection

EMI filter

Elma CPCI backplanes have excellent EMI properties. They are designed in a way to allow virtually zero crosstalk and extra low HF radiation. These features are realized thanks to an optimized structure with different types of capacitors well distributed on the entire surface of the backplane.

Pinout 12-way header (FCON):

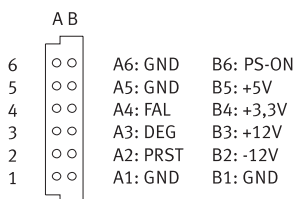

PAPARAMETERS

CLIMATIC

- Operating temperature -40 °C up to +85 °C
- Storage temperature -55 °C up to +85 °C
- Climatic conditions category to IEC 68/1: 25/085/21

MECHANICAL

- Flammability:
 - PCB: UL 94 V-0
 - Connectors: UL 94 V-0/-1
- Vibration:
 - According to DIN 41640 part 15: 10 Hz to 500 Hz 5 g rms
 - Impact (10 impacts per axis x,y,z) 50 g, 6 ms
- Layerstackup 10 layers/8 layers (2 Slot)
- Connector: 2 mm pitch, 7 rows,
 - Quality class 2 compliant to spec. IEC 61076-4-101 and BELLCORE GR-1217-CORE
 - Insertion force 0.75N and extraction force 0.15 N of every contact

ELECTRICAL

- According to PICMG 2.0 R.3.0
- VI/O configurable to +3.3 V or +5 V (+5 V factory settings)
- Clock frequency: 33 MHz or 66 MHz (2-5 Slot)
- Bus width: 32/64 bit
- Data transfer rate: max. 533 Mbyte/s (66 MHz/64 bit)
- Impedance Z0 without connectors and daughter cards: 65 Ohm +/-10 %
- Termination with Schottky Diode Array: only optional for 8 slot with rear card
- Current carrying capacity of power planes
 - +3.3 V/GND: 10 A/slot
 - +5 V/GND: 8 A/slot
- Max. voltage drop (center to boardout): 20 mV

AVAILABLE SLOTS

No. of slot	2	3	4	5	6	7	8
PCB width (mm)	39.64	59.96	80.3	100.6	120.92	141.24	161.56

CompactPCI 6U

FEATURES

- Compliant with
 - PICMG 2.0 R3.0 CPCI Core Specification
 - PICMG 2.1 R2.0 Hot Swap Specification
 - PICMG 2.9 R1.0 System Management Specification
- System slot right or left
- Modular power system
 - 2 to 3 slot powered via:
 - Fastons
 - ATX cable
 - 4 to 8 slot powered via:
 - ATX cable
 - M3 power bolts (cable lugs, washer and nuts enclosed)
 - Positronic PCI H47 (pass through contacts enclosed)
 - DIN 41612 type M (pass through contacts enclosed)
- Shrouds: P3 to P5; P2 to P5 (only for 32 bit Backplanes)
- 2 slot 8-layer construction; 3-8 slot 10-layer construction
- Number of slots: 2-8
- 10-21 slots available with cPCI to cPCI Bridge
- Virtually zero crosstalk
- Fastons for supplying HDD and fans
- Decoupling of the DC voltages far beyond 1 GHz (act as EMI-filter)
- Hot swap capability
- PCB height 262.05 mm
- PCB thickness 4.4 mm
- Connector for status signals "FCON"
 - Part number of mating connector including 1.0m cable, open end: 008-083
- Service life (MTBF according to MIL-HDBK 217F):

4 Slot	660.000 h
8 Slot	330.000 h



ORDER CODE

809 2 - - 6 0

option	code and description	note
System Slot	5 - left side 6 - right side	
Clock frequency	0 - 33 MHz, V(I/O) +5 V 6 - 66 MHz, V(I/O) +3.3 V	2-5 slot
Number of slots	02 to 08	
Bridge	6 - without bridge	
Power connection	6 - Fastons	2-3 slot
	8 - Power bolts	4-8 slot
	9 - DIN 41612 Type M connector	4-8 slot
	H - ATX cable	2-8 slot
	J - Positronic PCI H47	4-8 slot
Bus width	0 - 64 bit 1 - 32 bit	on request
Contact plating	0 - Power inputs tinned IEC pins gold-plated class 2	

GENERAL

CompactPCI (CPCI) is the specification for an industrial computer bus developed by PCI Industrial Computer Manufacturers Group (PICMG). CPCI is an adaptation of the Peripheral Component Interconnect (PCI) for industrial and/or embedded applications that require a more robust mechanical form factor than Desktop PCI.

Elma offers backplanes for operation at 33 MHz with 2-8 slots. Backplanes with 2-5 slots are available for 66 MHz bus frequency. All Elma backplanes have 64-bit routing and are hot swap capable.

Connectors

The CompactPCI connector is a shielded 2 mm pitch and 5+2 rows connector compliant to IEC 917 and IEC 61076-4-101. The connector includes the following features:

- Coding mechanism and guiding device for rear cards
- Pin staging for hot swap
- Shrouds for rear I/O
- Shielding for EMI/RFI protection

EMI filter

Elma CPCI backplanes have excellent EMI properties. They are designed in a way to allow virtually zero crosstalk and extra low HF radiation. These features are realized thanks to an optimized structure with different types of capacitors well distributed on the entire surface of the backplane.

Pinout 12-way header (FCON):

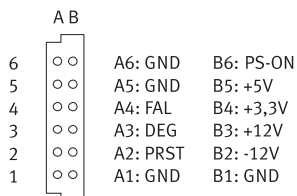

PAPRAMETERS

CLIMATIC

- Operating temperature -40 °C up to +85 °C
- Storage temperature -55 °C up to +85 °C
- Climatic conditions category to IEC 68/1: 25/085/21

MECHANICAL

- Flammability:
 - PCB: UL 94 V-0
 - Connectors: UL 94 V-0/-1
- Vibration:
 - According to DIN 41640 part 15: 10 Hz to 500 Hz 5 g rms
 - Impact (10 impacts per axis x,y,z) 50 g, 6 ms
- Layerstackup 10 layers/8 layers (2 Slot)
- Connector: 2 mm pitch, 7 rows,
 - Quality class 2 compliant to spec. IEC 61076-4-101 and BELLCORE GR-1217-CORE
 - Insertion force 0.75 N and extraction force 0.15 N of every contact

ELECTRICAL

- According to PICMG 2.0 R.3.0
- VI/O configurable to +3.3 V or +5 V (+5 V factory settings)
- Clock frequency: 33 MHz or 66 MHz (2-5 Slot)
- Bus width: 32/64 bit
- Data transfer rate: max. 533 Mbyte/s (66 MHz/64 bit)
- Impedance Z0 without connectors and daughter cards: 65 Ohm +/-10%
- Termination with Schottky Diode Array: only optional for 8 slot with rear card
- Current carrying capacity of power planes
 - +3.3 V/GND: 10 A/slot
 - +5 V/GND: 8 A/slot
- Max. voltage drop (center to boardout): 20 mV

AVAILABLE SLOTS

No. of slot	2	3	4	5	6	7	8
PCB width (mm)	39.64	59.96	80.3	100.6	120.92	141.24	161.56

cPCI Backplane with H.110 bus

FEATURES

- Compliant with
 - PICMG 2.0 R3.0 CPCI Core Specification
 - PICMG 2.5 R.1.0 Computer Telephony Specification
 - PICMG 2.1 R2.0 Hot Swap Specification
 - PICMG 2.9 R1.0 System Management Specification
- System slot right
- System slot can be isolated from H.110-bus (8 slot Backplane only)
- Modular power system
 - 4 to 8 slot powered via:
 - ATX cable
 - M3 power bolts (cable lugs, washer and nuts enclosed)
 - Positronic PCI H47 (pass through contacts enclosed)
 - DIN 41612 type M (pass through contacts enclosed)
- P4 telecom power bus voltages via M3 bolts
- Number of slots: 4, 8 (others on request)
- 10-layer construction
- Virtually zero crosstalk
- Fastons for supplying HDD and fans
- Decoupling of the DC voltages far beyond 1 GHz (act as EMI-filter)
- Hot swap capability
- PCB height 262.05 mm
- PCB thickness 4.4 mm
- Connector for status signals "FCON"
 - Part number of mating connector including 1.0 m cable, open end: 008-083
- Service life (MTBF according to MIL-HDBK 217F):

4 Slot	660.000 h
8 Slot	330.000 h

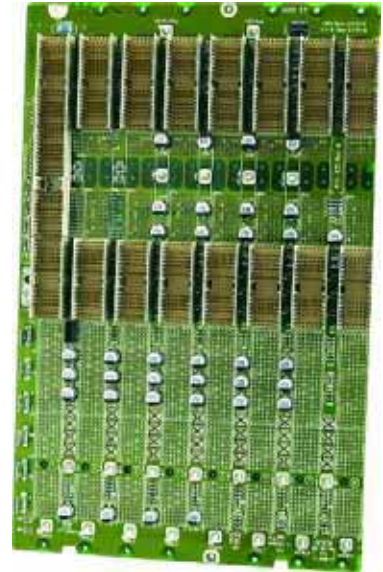

ORDER CODE

8 9 7 2 - - 6 0

option	code and description	note
System Slot	3 - right without H.110 2 - right with H.110	8 slot only
Clock frequency	0 - 33 MHz, V(I/O) +5 V 6 - 66 MHz, V(I/O) +3.3 V	2-5 slot
Number of slots	04, 08	others on request
Bridge	6 - without bridge	
Power connection	8 - Power bolts 9 - DIN 41612 Type M connector H - ATX cable J - Positronic PCI H47	4-8 slot 4-8 slot 4-8 slot 4-8 slot
Bus width	0 - 64 bit 1 - 32 bit	on request
Contact plating	0 - Power inputs tinned IEC pins gold-plated class 2	

GENERAL

About Computer Telephony / H.110

The integration of computers and telecommunications has enabled a wide range of new communications applications. A key element in the development of computer-based communications equipment has been the addition of an telecom bus to existing cPCI Backplanes on the J4/P4 CompactPCI connector location.

The objective of this CT Bus specification is to provide a single telecom bus for the entire industry. A single, industry-wide CT Bus is driving new applications, reducing costs and expanding markets.

The H.100 CT Bus specification is targeted at CompactPCI form factor products.

It defines the utilization of CompactPCI user definable pins for the computer telephony functions of standard TDM bus, telephony rear IO, 48 VDC and ringing distribution in a 6U chassis environment to support the next generation of high capacity servers.

Pinout 12-way header (FCON):

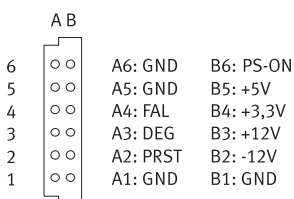

PAPRAMETERS

CLIMATIC

- Operating temperature -40 °C up to +85 °C
- Storage temperature -55 °C up to +85 °C
- Climatic conditions category to IEC 68/1: 25/085/21

MECHANICAL

- Flammability:
 - PCB: UL 94 V-0
 - Connectors: UL 94 V-0/-1
- Vibration:
 - According to DIN 41640 part 15: 10 Hz to 500 Hz 5 g rms
 - Impact (10 impacts per axis x,y,z) 50 g, 6 ms.
- Layerstackup 10 layers/8 layers (2 Slot)
- Connector: 2 mm pitch, 7 rows,
 - Quality class 2 compliant to spec. I EC 61076-4-101 and BELLCORE GR-1217-CORE
 - Insertion force 0.75 N and extraction force 0.15 N of every contact

ELECTRICAL

- According to PICMG 2.0 R.3.0 and PICMG 2.5 R.1.0
- VI/O configurable to +3.3 V or +5 V (+5 V factory settings)
- Clock frequency: 33 MHz or 66 MHz (2-5 Slot)
- Bus width: 32/64 bit
- Data transfer rate: max. 533 Mbyte/s (66 MHz/64 bit)
- Impedance Z0 without connectors and daughter cards: 65 Ohm +/-10 %
- Termination with Schottky Diode Array: only optional for 8 slot with rear card
- Current carrying capacity of power planes
 - +3.3 V/GND: 10 A/slot
 - +5 V/GND: 8 A/slot
- Max. voltage drop (center to boardout): 20 mV

AVAILABLE SLOTS (OTHERS ON REQUEST)

No. of slot	4	8
PCB width (mm)	80.3	166.64

cPCI Backplane with Bridge

FEATURES

- In combination with Elma standard cPCI backplanes only
- Bridge module for the rear side of the backplane (pluggable)
- Supports +3.3 V or +5 V input (onboard voltage regulator)
- Provides 7 clock signals for the secondary backplane
- Arbitration for 7 devices on the secondary backplane possible
- Bus width: 32/64 bit
- Based on the Intel PCI-to-PCI bridge fw21154ae
- 8-layer construction
- Automatic detection 32/64 bit systems
- Bus frequency: 33 MHz (66 MHz on request)
- Dimensions of bridge module:
 - PCB height 95.1 mm
 - PCB width 78.96 mm
 - PCB thickness 2.7 mm
- System configurations with one bridge:
 - 7 slot (primary) + 3-7 slot (secondary) backplane
- System configurations with two bridges:
 - 7 slot (primary) + 7 slot (middle) + 3-7 slot (tertiary) backplane
- Order code of bridge module:
 - 80983-0000 (left to right)
 - 80984-0000 (right to left)

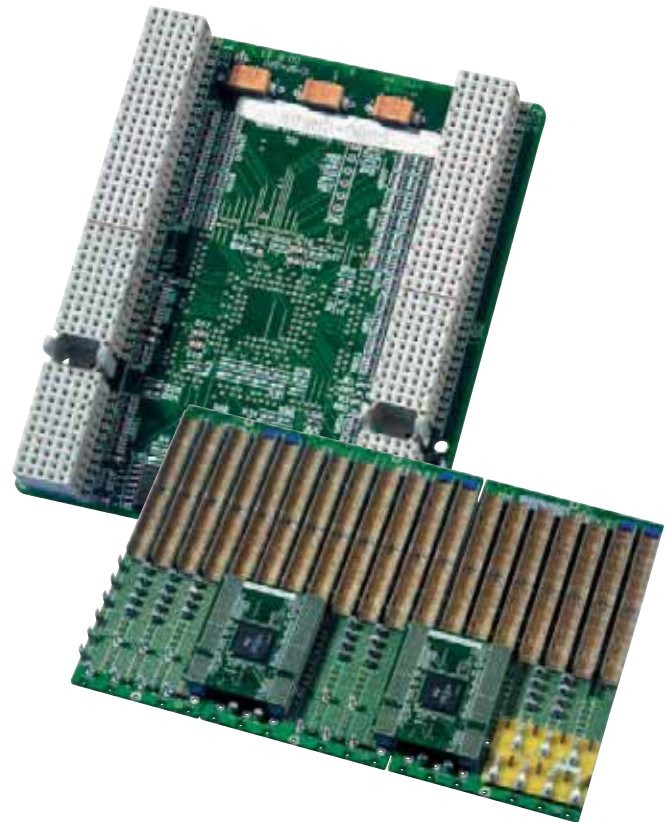

ORDER CODE

809 3 - - B 8 0 0

option	code and description	note
Height, System Slot	3 - 3U, left 4 - 3U, right 5 - 6U, left 6 - 6U, right	
Clock frequency	0 - 33 MHz, V(I/O) +5 V 6 - 66 MHz, V(I/O) +3.3 V	2-5 slot, on request
Number of slots	10 to 21	
Bridge	B - with bridge	
Power connection	8 - Power bolts	
Bus width	0 - 64 bit	
Contact plating	0 - Power inputs tinned IEC pins gold-plated class 2	

GENERAL

CompactPCI (CPCI) is the specification for an industrial computer bus developed by PCI Industrial Computer Manufacturers Group (PICMG). CPCI is an adaptation of the Peripheral Component Interconnect (PCI) for industrial and/or embedded applications that require a more robust mechanical form factor than Desktop PCI.

Elma offers backplanes for operation at 33 MHz with 2-8 slots. Backplanes with 2-5 slots are available for 66 MHz bus frequency. All Elma backplanes have 64-bit routing and are hot swap capable.

CPCI bridge

Up to three backplanes can be connected together with the bridge. Therefore the number of slots can be increased up to 21 slots. No slots are occupied by the bridge module.

EMI filter

Elma CPCI backplanes have excellent EMI properties. They are designed in a way to allow virtually zero crosstalk and extra low HF radiation. These features are realized thanks to an optimized structure with different types of capacitors well distributed on the entire surface of the backplane.

Bridge Module Overview

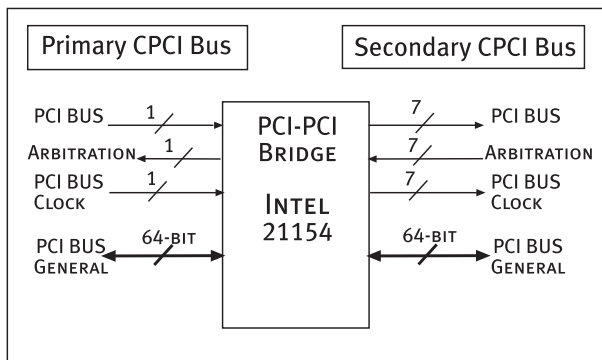

PAPRAMETERS

CLIMATIC

- Operating temperature 0 °C up to +70 °C
- Storage temperature -45 °C up to +70 °C
- Climatic conditions category to IEC 68/1: 25/085/21

MECHANICAL

- Flammability:
 - PCB: UL 94 V-0
 - Connectors: UL 94 V-0/-1
- Vibration:
 - According to DIN 41640 part 15: 10 Hz to 500 Hz 5 g rms
 - Impact (10 impacts per axis x,y,z) 50 g, 6 ms
- Layerstackup 8 layers
- Connector: 2 mm pitch, 7 rows,
 - Quality class 1 compliant to spec. IEC 61076-4-101 and BELLCORE GR-1217-CORE
- Insertion force 0.75 N and extraction force 0.15 N of every contact

ELECTRICAL

- Clock frequency: 33 MHz
- Bus width: 32/64 bit
- Impedance Z0 without connectors and daughter cards: 65 Ohm +/-10 %
- Possibility to use different VI/O voltage levels on primary and secondary backplane
- Onboard voltage regulator to supply +3.3 V for the bridge driver
- JTAG interface according to IEEE1149.1

AVAILABLE SLOTS

with one bridge, System slot left

No. of slot	10	11	12	13	14
PCB width (mm)	203.2	223.5	243.8	264.2	284.8

with two bridges, System slot left

No. of slot	17	18	19	20	21
PCB width (mm)	345.4	365.7	386.1	406.4	426.7

with one bridge, System slot right

No. of slot	14
PCB width (mm)	284.8

with two bridges, System slot right

No. of slot	21
PCB width (mm)	426.7

PXI 3U

FEATURES

- Compliant with
 - PICMG 2.0 R3.0 CPCI Core Specification
 - PXI SA R2.1
 - PICMG 2.1 R2.0 Hot Swap Specification
 - PICMG 2.9 R1.0 System Management Specification
- System slot left
- Star trigger on slot 2
- Modular power system:
 - ATX cable
 - M3 power bolts (cable lugs, washer and nuts enclosed)
 - Positronic PCI H47 (pass through contacts enclosed)
 - DIN 41612 type M (pass through contacts enclosed)
- 10-layer construction
- Number of slots: 8
- Virtually zero crosstalk
- Fastons for supplying HDD and fans
- Decoupling of the DC voltages far beyond 1GHz (act as EMI-filter)
- Hot swap capability
- PCB height 128.7 mm
- PCB thickness 3.5 mm
- PCB width 161.56 mm
- Connector for status signals "FCON"
 - Part number of mating connector including 1.0 m cable, open end: 008-083

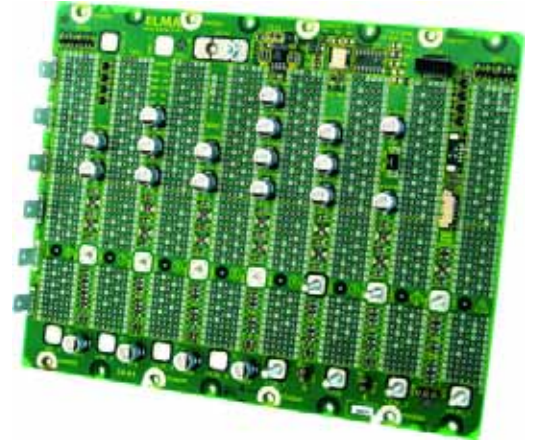

ORDER CODE

859 3 2 - 0 - 6 0 0

option	code and description	note
System Slot	3 - left side	
Clock frequency	0 - 33 MHz, V(I/O) +5 V	
Slots	08	
Bridge	6 - without bridge	
Power connection	8 - Power bolts 9 - DIN 41612 Type M connector H - ATX cable K - Postronic PCI H47	
Bus width	0 - 64 bit	
Contact plating	0 - Power inputs tinned IEC pins gold-plated class 2	

GENERAL

About PXI

The PCI eXtensions for Instrumentation (PXI) specification defines a rugged PC-based platform for measurement and automation systems. It combines the high-speed PCI bus with integrated timing and triggering designed specifically for measurement and automation applications to deliver significant performance improvements over older architectures.

By using the de facto standard PCI bus, PXI modular instrumentation systems can benefit from widely available software and hardware components. The software applications and operating systems that run on PXI systems are already familiar to users because they are already in use on common desktop computers. PXI meets your needs by adding rugged industrial packaging, plentiful slots for I/O, and features that provide advanced timing and triggering capabilities.

Special PXI features

A System Reference Clock (10 MHz TTL clock) provides a built-in common reference clock for synchronization of multiple modules in a measurement or control system.

PXI Trigger Bus: Eight trigger bus lines for synchronization and communication between modules.

Star Trigger Bus has an independent trigger line for each slot oriented in a star configuration from a special star trigger slot (slot 2 in any PXI chassis). This feature addresses high-speed synchronization where you can distribute start/stop trigger signals from the master measurement module in the star trigger slot with low delay and skew.

The PXI Local Bus is a daisy-chained bus that connects each peripheral slot with its adjacent peripheral slots to the left and right.

PAPRAMETERS

CLIMATIC

- Operating temperature -40 °C up to +85 °C
- Storage temperature -55 °C up to +85 °C
- Climatic conditions category to IEC 68/1: 25/085/21

MECHANICAL

- Flammability:
 - PCB: UL 94 V-0
 - Connectors: UL 94 V-0/-1
- Vibration:
 - According to DIN 41640 part 15: 10 Hz to 500 Hz 5 g rms
 - Impact (10 impacts per axis x,y,z) 50 g, 6 ms.
- Layerstackup 10 layers
- Connector: 2 mm pitch, 7 rows,
 - Quality class 2 compliant to spec. IEC 61076-4-101 and BELLCORE GR-1217-CORE
 - Insertion force 0.75 N and extraction force 0.15 N of every contact

ELECTRICAL

- According to PICMG 2.0 R.3.0 and PXI SA R2.1
- VI/O configurable to +3.3 V or +5 V (+5 V factory settings)
- Clock frequency: 33 MHz
- Bus width: 64 bit
- Data transfer rate: max. 533 Mbyte/s (66 MHz/64 bit)
- Impedance Z0 of cPCI signals without connectors and daughter cards: 65 Ohm +/-10 %
- Trigger bus terminated with Schottky Diode Array
- Current carrying capacity of power planes
 - +3.3 V/GND: 10 A/slot
 - +5 V/GND: 8 A/slot
- Max. voltage drop (center to boardout): 20 mV

AVAILABLE SLOTS

No. of slot 8

PCB width (mm) 161.56

cPCI Extenderboard

FEATURES

- To test peripheral cPCI boards
- 8-layer construction
- Compliment with PICMG 2.0 CompactPCI Specification Rev. 3.0
- cPCI signals from P1 and P2 extended using PCI to PCI Bridge
- Based on the Intel PCI-to-PCI bridge fw21154be
- Bus frequency: 33 MHz (standard) or 66 MHz
- All pins from P3, P4 and P5 are routed 1:1
- Signals can be individually switched on/off via SMD switches
- Characteristic impedance 65 Ohm +/-10 %
- Handles for insertion/extraction of the daughter card
- Two test points for each signal, one placed before the switch, one after the switch
- Table in silkscreen showing the mapping of the signals to the SMD switches
- PCB height 233.4 mm
- Extender depth 323.1 mm (163.1 mm out of card cage)
- PCB thickness 2.2 mm (with edges milled to 1.6mm for use in standard card guides)
- Access to GND, +3.3 V, +5 V, +12 V, -12 V via fastons
- VI/O voltage selectable between +3.3 and +5 V

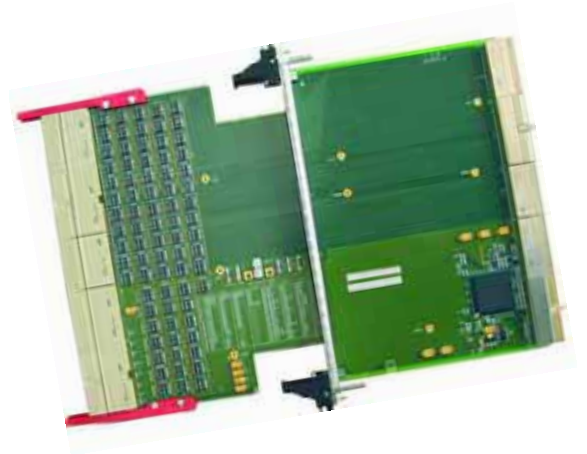

ORDER CODE

80992-0000 (64 Bit, 33 MHz)

GENERAL

CompactPCI (CPCI) is the specification for an industrial computer bus developed by PCI Industrial Computer Manufacturers Group (PICMG). CPCI is an adaptation of the Peripheral Component Interconnect (PCI) for industrial and/or embedded applications that require a more robust mechanical form factor than Desktop PCI.

Elma offers backplanes for operation at 33 MHz with 2-8 slots. Backplanes with 2-5 slots are available for 66 MHz bus frequency. All Elma backplanes have 64-bit routing and are hot swap capable.

Connectors

The CompactPCI connector is a shielded 2 mm pitch and 5+2 rows connector compliant to IEC 917 and IEC 61076-4-101. The connector includes the following features:

- Coding mechanism and guiding device for rear cards
- Pin staging for hot swap
- Shrouds for rear I/O
- Shielding for EMI/RFI protection

PAPRAMETERS**CPCI EXTENDERBOARD**

The cPCI extender board supports the testing of daughter boards. It is plugged into the backplane in the slot for the daughter board. The daughter board is plugged onto the extender board outside the card cage, making it more easily accessible. All contacts with the backplane can be controlled individually by switches. The test sector offers easy access, with tapping points right and left of the switches for all signal lines. GND, +3.3 V, +5 V, +12 V and -12 V are linked to power layers and each is accessible through a faston connector.

An active PCI to PCI bridge ensures maximum signal integrity for cPCI signals on P1 & P2. Insertion / extraction handles are incorporated, and the card edges are milled to 1.6 mm to ensure compatibility with standard card guides.

Complying with PICMG 2.0, Rev 3.0, the extender provides a convenient way to measure and isolate each signal line, and includes a silkscreen table that maps each signal to its isolation switch. With high integrity signal paths for all P1 - P5 pins, support for 32 bit and 64 bit devices, and both 33 MHz and 66 MHz busses, the active extender is designed to deliver a convenient and reliable debug and test tool to cPCI board designers and system integrators.

CompactPCI Power Options

POWER CONNECTION VIA POWERBOLTS AND FASTONS (M3 CABLE LUGS, WASHER AND NUTS ENCLOSED)



6 – Fastons, 2-3 slot
10 A max./Faston



8 – Power bolts, 4-8 slot
30 A max./M3 Power bolts



H – ATX cable, 2-8 slot

POWER CONNECTION VIA INTERCONNECTION- AND POWER BOARD



9 – DIN 41612 Type M, 4-8 slot
3U: Lower position
6U: Upper und lower position



J – Positronic PCIH47, 4-8 slot
6U: Upper position
L – Positronic PCIH47, 4-8 slot
6U: 2x Upper position

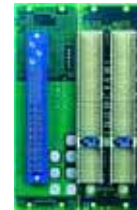

K – Positronic PCIH47, 4-8 slot
3U: Lower position
M – Positronic PCIH47, 4-8 slot
6U: 2x Lower position

POWER CONNECTION "STAND ALONE" (HAS TO BE WIRED)

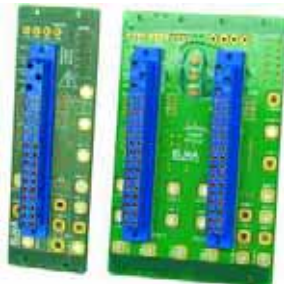

Power Boards 3U
020-927 (8HP, 1x PCIH47)
020-071 (16HP, 2x PCIH47)



Power Boards 6U
020-929 (8HP, 1x PCIH47)
019-748 (16HP, 2x PCIH47)

CompactPCI Accessories

POWER SUPPLIES



AC version
308-00200ac: 3U, 8HP, 200 W
608-00400ac: 6U, 8HP, 400 W



DC version
308-00200dc: 3U, 8HP, 200 W
608-00400dc: 6U, 8HP, 400 W

MISCELLANEOUS



008-083
12 pin mating connector for "FCON"
(1 m cable AWG30, open end)



021-014
10x coding keys VI/O
+3,3 V (yellow)



020-027: 2 to 3 slot
013-585: 4 to 8 slot
ATX-Cable (length: 35 cm)

VITA 41 VXS

FEATURES

- Compliant with the latest VITA standards
 - VITA 1.7-2003 Increased Current Level For 96 Pin & 160 Pin DIN/IEC Connector
 - VITA 41.0-200x VXS VMEbus Switched Serial Standard
 - VITA 41.10-200x Live Insertion System Requirements for VITA 41 Boards Trial Use Standard
 - VITA 41.11-200x Rear Transition Module Standard for VXS VMEbus Switched Serial Payload
 - ANSI/VITA 38-2003 System Management Draft Standard
 - ANSI/VITA 1.1-1997 VME64x Standard as modified by VITA 41.0 (P0/J0 connector and Switch Slots)
 - ANSI/VITA 1.5-2003 2eSST (Source Synchronous Transfer)
- One or two VITA 41.x Switch Slots
- Up to 18 VITA 41.x Payload Slots
- Each Switch Slot route one standard 4x link (8 differential pairs) to each Payload Slot
- Switched serial traffic over P0 of VME64x backplane
- High-speed Multi-Gig RT-2 connectors for up to 6.4 Gbps data rate are used in the Switch Slots (P2-P5) and in the Payload Slots (P0) Compatible with VME64x standard line cards
- Live Insertion support for VITA 41 boards as well as for standard VME64x boards (8 slot version only)
- Keying modules for all VXS slots according VITA 41 Specification
- Alignment mechanism for all VXS slots according VITA 41 Specification
- System management IPMB bus per VITA 38
- Support for Rear Transition Modules in the Payload Slots according to VITA 41.11 Specification

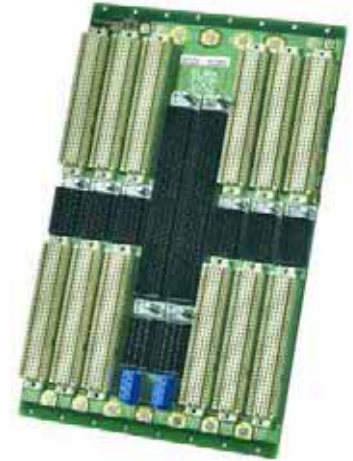

ORDER CODE

023-078	5-slot 7U single star topology
023-079	5-slot 7U mesh topology
022-817	8-slot 6U dual star topology
023-310	12-slot 7U dual star topology

Other versions e.g. Switchless or Hybrid on request.

ABOUT VITA 41

The VXS Switched Serial standard is a new VITA initiative to advance VME technology. Fully reverse compatible to VME/VME64x, VXS utilizes a new 6.4 Gbps high-speed connector across the P0 section of a VME64x backplane. The new connector allows the use of switched fabric signals for higher bandwidth and reliability.

The VXS backplane allows three options:

- Plug in standard VME64x cards for parallel bus use
- Integrate new payload and switch cards for parallel bus and switch fabric transport
- Switch fabric transport only

The VXS spec allows four differential serial pairs per direction link over P0, and supports up to two such ports on each VMEbus card.

The subsets of VITA 41 include InfiniBand (VITA 41.1), Rapid I/O (VITA 41.2), and may include GigaBit Ethernet (VITA 41.3), PCI Express (VITA 41.4) and StarFabric (VITA 41.5).

VITA 31.1 Gigabit Ethernet on VME64x

FEATURES

- 10/100/1000BASE-T Ethernet switched network on a VME64x backplane
- 2 redundant VITA 31.1 Fabric Slots, right side of backplane
- 6 VITA 31.1 Node Slots
- Increase bandwidth and reliability
- Switches 100% compatible to PICMG 2.16
- Standard VME64x / cPCI connectors
- Automatic active Daisy Chain
- Passive inboard termination (basic current consumption 1.5A)
- Power input: M3/M4 power bolts (M3/M4 cable lugs, washer and nuts enclosed)
- 10-layer construction
- ANSI/VITA 1.1-1997 VME64x Standard compliant
- According to VITA 1.7 Increased Current Level For 96 Pin & 160 Pin DIN/IEC Connector



ORDER CODE

021-980

ABOUT VITA 31.1

VITA 31.1 defines a pinout and interconnection methodology for implementing a 10/100/1000BASE-T Ethernet switched network on a VME64x backplane. The PICMG 2.16 Packet Switched backplane specification adds a switched network based on Gigabit Ethernet to cPCI backplanes. The cPCI P3 connector has two Gigabit Ethernet ports for improved performance and redundancy. The VME64x P0 connector is identical to the cPCI P3 connector and has the same placement on the backplane. VITA 31.1 adopts the PICMG 2.16 P3 connector pinout for use on VME64x boards. It also adopts the definition of the fabric card described in PICMG 2.16. PICMG 2.16 compliant systems and VITA 31.1 systems can use the same switched fabric boards.

The routing topology is a star one: each Node Slot is connected with Ethernet Links to the Fabric Slots. Each of these links is used to transmit packets only between one Fabric Slot and one Node Slot. There are no bussed lines used between the Node Slots and Fabric Slots, only point to point connections. Switches for a Packet Switching (PICMG 2.16) backplane are 100% compatible to a VITA 31.1 backplane. Node Slots are similar to PICMG 2.16, where the Ethernet ports were assigned to the P3-cPCI connectors, in a VITA 31.1 backplane the Ethernet ports are assigned to the P0 connectors that for a standard VME64x backplane were used only as I/O connectors. Each port consist of four differential pairs (two Tx and two Rx).

VMEbus J1 Classic

FEATURES

- Various daisy-chain solutions
- Configured for "high-power" applications (different solutions)
- 8-layer construction
- Optimum separation of signal lines on inner layers
- Characteristic impedance 55 Ohm +/- 10 %
- Inboard termination (active/passive)
- Basic current consumption:
 - 20 mA for active termination
 - 1.2 A for passive termination
- Minimum GND-Shift due to low inductance current distribution with high surface capacity
- Effective decoupling to enhance dynamic current response
- Sense signals via fastons
- PCB height 129.5 mm
- PCB thickness 3.2 mm
- Connector for status signals (Fail, Reset, GND, +5 V)
 - Part number of mating connector including 1.0 m cable, open end: 002-858
- Service life (MTBF according to MIL-HDBK 217F):

5 slot	1 564 000 h
21 slot	467 000 h

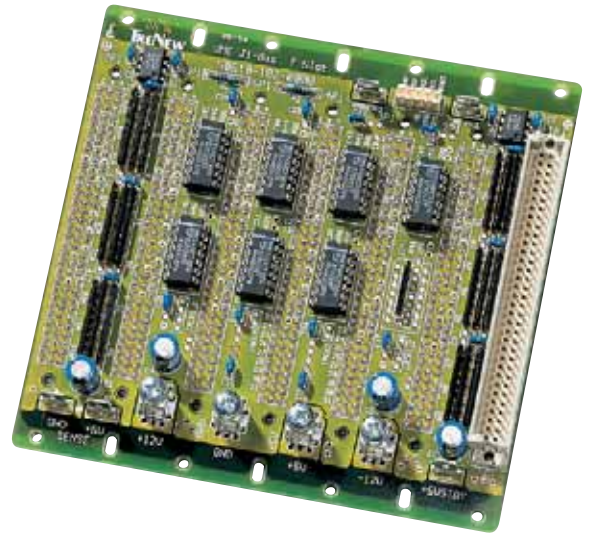

ORDER CODE

50510- [] [] - [] [] [] 0

option	code and description	note
Termination	1 - active inboard 2 - passive inboard	
Slots	02 to 21	
Daisy Chain	0 - automatic active 2 - jumper on both sides	
Power connection	0 - 70 A M4 Power bolts 1 - 12 A faston/M4 screw 6 - 12 A faston	
Shroud (1 J1)	0 - without latches 1 - optional latchable	Ejectors not included in delivery
Contact plating	0 - Power inputs tinned DIN pins gold-plated class 2	

GENERAL

Mechanical Design

The VMEbus is designed for 19-inch rack technology and supports bus lengths of up to 21 slots.

In this system, slot 1 is on the left of the rack, with the rest of the bus extending to the right. The daughter boards are connected to the backplane with 96-pin connectors to DIN 41612. Three configurations of the VMEbus are available for different applications.

J1-plane

The basic configuration is the 3U high (Single Eurocard) J1 plane. This plane provides all the address, data and control lines, and is fully capable of operating as a standalone bus.

J2-plane

For larger computer structures, the basic configuration can be extended with a second plane, the J2 plane, also 3U high. It lies directly below the J1 plane in the 19-inch rack and extends the data and address space of the computer system. In addition, the user is provided with 64 freely-definable inputs/outputs per slot, which can be connected using interconnection points on the rear of the backplane.

The J2 plane is only used as an extension of the VMEbus from the J1-plane and cannot be operated as a standalone bus.

J1/J2-Monolithic

Monolithic backplanes combine the J1 and J2 planes of the VMEbus on a single printed circuit board. Preference should be given to these PCBs for new designs which access the J2 plane.

Because of its continuous power supply layers, the monolithic backplane is superior to two separate J1 and J2 planes, particularly with respect to dynamic current distribution.

PAPRAMETERS

CLIMATIC

- Operating temperature
Passive termination: -40 °C to +85 °C
Active termination: 0 °C to +50 °C
- Storage temperature -55 °C to +85 °C
- Climatic conditions according IEC 68/1: 25/085/21

MECHANICAL

- Flammability:
 - PCB: UL 94 V-0
 - Connectors: UL 94 V-0/-1
- Vibration:
 - According to DIN 41640 Part 15:
10 Hz - 500 Hz 5 g rms
 - Impact (10 Impacts per axis x,y,z)
100 g, 6 ms
- Connectors DIN 41612, C96 type, class 2 with 400 connection cycles

ELECTRICAL

- Compliant to VMEbus Specification ANSI/VITA 1-1994
- Maximum data transfer rate 80 Mbyte/s for MBLT-protocol and 160 Mbyte/s for 2e-protocol

AVAILABLE SLOTS

No. of slot	2	3	4	5	6	7	8	9
PCB width (mm)	39,64	53.5	73.7	93.9	114.3	134.6	155.0	175.3
No. of slot	10	11	12	13	14	15	16	17
PCB width (mm)	195.6	215.6	236.2	256.5	276.2	297.2	317.5	337.8
No. of slot	18	19	20	21				
PCB width (mm)	358.1	378.5	398.8	419.1				

VMEbus J2 Classic

FEATURES

- Configured for „high-power“ applications (different solutions)
- 4-layer construction
- Optimum separation of signal lines on inner layers
- Characteristic impedance 55 Ohm +/-10 %
- Inboard termination (active/passive)
- Basic current consumption:
 - 20 mA for active termination
 - 0.3 A for passive termination
- Minimum GND-Shift due to low inductance current distribution with high surface capacity
- Effective decoupling to enhance dynamic current response
- Optional latchable shrouds with ejectors with interlock facility to hold I/O plug securely
- Part number of ejectors:
 - 017-815 10x Type C (black)
 - 017-816 10x Type R (green)
- PCB height 129.5 mm
- PCB thickness 3.2 mm

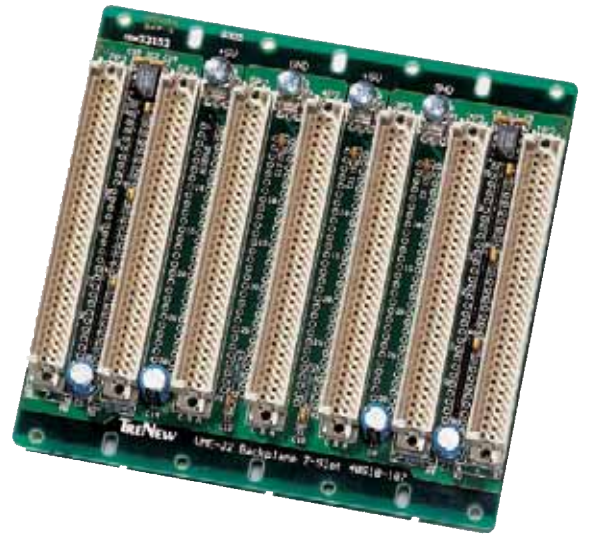

ORDER CODE

40510- - 3 0

option	code and description	note
Termination	1 - active inboard 2 - passive inboard	
Slots	03 to 21	
Daisy Chain	3 - no daisy chain	
Power connection	0 - 70 A M4 Power bolts 1 - 12 A faston/M4 screw 6 - 12 A faston	
Shroud (n J2)	0 - without latches 1 - optional latchable	Ejectors not included in delivery
Contact plating	0 - Power inputs tinned DIN pins gold-plated class 2	

GENERAL

Mechanical Design

The VMEbus is designed for 19-inch rack technology and supports bus lengths of up to 21 slots.

In this system, slot 1 is on the left of the rack, with the rest of the bus extending to the right. The daughter boards are connected to the backplane with 96-pin connectors to DIN 41612. Three configurations of the VMEbus are available for different applications.

J1-plane

The basic configuration is the 3U high (Single Eurocard) J1 plane. This plane provides all the address, data and control lines, and is fully capable of operating as a standalone bus.

J2-plane

For larger computer structures, the basic configuration can be extended with a second plane, the J2 plane, also 3U high. It lies directly below the J1 plane in the 19-inch rack and extends the data and address space of the computer system. In addition, the user is provided with 64 freely-definable inputs/outputs per slot, which can be connected using interconnection points on the rear of the backplane.

The J2 plane is only used as an extension of the VMEbus from the J1-plane and cannot be operated as a standalone bus.

J1/J2-Monolithic

Monolithic backplanes combine the J1 and J2 planes of the VMEbus on a single printed circuit board. Preference should be given to these PCBs for new designs which access the J2 plane.

Because of its continuous power supply layers, the monolithic backplane is superior to two separate J1 and J2 planes, particularly with respect to dynamic current distribution.

PAPRAMETERS

CLIMATIC

- Operating temperature
Passive termination: -40 °C to +85 °C
Active termination: 0 °C to +50 °C
- Storage temperature -55 °C to +85 °C
- Climatic conditions according IEC 68/1: 25/085/21

MECHANICAL

- Flammability:
 - PCB: UL 94 V-0
 - Connectors: UL 94 V-0/-1
- Vibration:
 - According to DIN 41640 Part 15:
10 Hz - 500 Hz 5 g rms
 - Impact (10 Impacts per axis x,y,z) 100 g, 6 ms
- Connectors DIN 41612, C96 type, class 2 with 400 connection cycles

ELECTRICAL

- Compliant to VMEbus Specification ANSI/VITA 1-1994
- Maximum data transfer rate 80 Mbyte/s for MBLT-protocol and 160 Mbyte/s for 2e-protocol

AVAILABLE SLOTS

No. of slot	3	4	5	6	7	8	9	10
PCB width (mm)	53.5	73.7	93.9	114.3	134.6	155.0	175.3	195.6

No. of slot	12	13	14	16	20	21
PCB width (mm)	236.2	256.5	276.2	317.5	398.8	419.1

VMEbus Monolithic *Classic*

FEATURES

- Various daisy-chain solutions
- Configured for „high-power“ applications (different solutions)
- 8-layer construction
- Optimum separation of signal lines on inner layers
- Characteristic impedance 55 Ohm +/-10 %
- Inboard termination (active/passive)
- Basic current consumption:
 - 20 mA for active termination
 - 1.5 A for passive termination
- Minimum GND-Shift due to low inductance current distribution with high surface capacity
- Effective decoupling to enhance dynamic current response
- Sense signals via fastons
- PCB height 262.9 mm
- PCB thickness 3.2 mm
- Connector for status signals (Fail, Reset, GND, +5 V)
 - Part number of mating connector including 1.0m cable, open end: 002-858
- Optional latchable shrouds with ejectors with interlock facility to hold I/O plug securely
- Part number of ejectors:
 - 017-815 10x Type C (black)
 - 017-816 10x Type R (green)
- Service life (MTBF according to MIL-HDBK 217F):
 - 5 slot 1 042 000 h
 - 21 slot 345 000 h

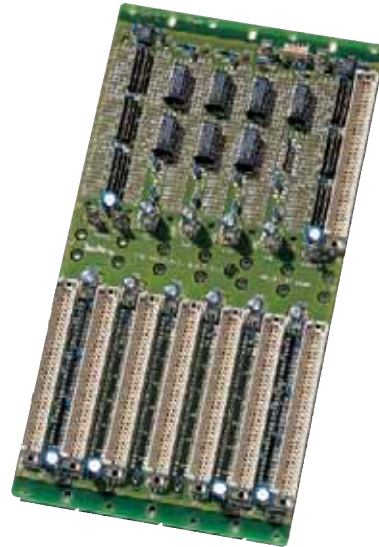

ORDER CODE

30510- [] [] - [] [] [] 0

option	code and description	note
Termination	1 - active inboard 2 - passive inboard	
Slots	02 to 21	
Daisy Chain	0 - automatic active 2 - jumper on both sides	
Power connection	0 - 70 A M4 Power bolts 1 - 12 A faston/M4 screw 6 - 12 A faston	
Shroud (1 J1, n J2)	0 - without latches 1 - optional latchable	Ejectors not included in delivery
Contact plating	0 - Power inputs tinned DIN pins gold-plated class 2	

GENERAL

Mechanical Design

The VMEbus is designed for 19-inch rack technology and supports bus lengths of up to 21 slots.

In this system, slot 1 is on the left of the rack, with the rest of the bus extending to the right. The daughter boards are connected to the backplane with 96-pin connectors to DIN 41612. Three configurations of the VMEbus are available for different applications.

J1-plane

The basic configuration is the 3U high (Single Eurocard) J1 plane. This plane provides all the address, data and control lines, and is fully capable of operating as a standalone bus.

J2-plane

For larger computer structures, the basic configuration can be extended with a second plane, the J2 plane, also 3U high. It lies directly below the J1 plane in the 19-inch rack and extends the data and address space of the computer system. In addition, the user is provided with 64 freely-definable inputs/outputs per slot, which can be connected using interconnection points on the rear of the backplane.

The J2 plane is only used as an extension of the VMEbus from the J1-plane and cannot be operated as a standalone bus.

J1/J2-Monolithic

Monolithic backplanes combine the J1 and J2 planes of the VMEbus on a single printed circuit board. Preference should be given to these PCBs for new designs which access the J2 plane.

Because of its continuous power supply layers, the monolithic backplane is superior to two separate J1 and J2 planes, particularly with respect to dynamic current distribution.

PAPRAMETERS

CLIMATIC

- Operating temperature
Passive termination: -40 °C to +85 °C
Active termination: 0 °C to +50 °C
- Storage temperature -55 °C to +85 °C
- Climatic conditions according IEC 68/1: 25/085/21

MECHANICAL

- Flammability:
 - PCB: UL 94 V-0
 - Connectors: UL 94 V-0/-1
- Vibration:
 - According to DIN 41640 Part 15:
10 Hz - 500 Hz 5 g rms
 - Impact (10 Impacts per axis x,y,z) 100 g, 6 ms
- Connectors DIN 41612, C96 type, class 2 with 400 connection cycles

ELECTRICAL

- Compliant to VMEbus Specification ANSI/VITA 1-1994
- Maximum data transfer rate 80 Mbyte/s for MBLT-protocol and 160 Mbyte/s for 2e-protocol

AVAILABLE SLOTS

No. of slot	2	3	4	5	6	7	8
PCB width (mm)	39.64	53.5	73.7	93.9	114.3	134.6	155.0
No. of slot	9	10	11	12	13	14	15
PCB width (mm)	175.3	195.6	215.6	236.2	256.5	276.2	297.2
No. of slot	16	18	19	20	21		
PCB width (mm)	317.5	358.1	378.5	398.8	419.1		

VME64x 6U

FEATURES

- Automatic active Daisy Chain
- Configured for „normal range“ power supply
- Power input: M3/M4 power bolts (M3/M4 cable lugs, washer and nuts enclosed)
- 10-layer construction
- Passive inboard termination (basic current consumption 1.5 A)
- Mounting holes for optional connection to Chassis GND
- Assembly with/without P0 connectors
- Characteristic impedance 55 Ohm +/-10 %
- Effective decoupling of the DC voltages far beyond 1 GHz (act as EMI-filter)
- Mechanical compliant to ANSI /IEEE 1101
- PCB height 262.9 mm
- PCB thickness 4.6 mm
- Connector for status signals "FCON"
 - Part number of mating connector including 1.0 m cable, open end: 008-083
- Service life (MTBF, MIL-HDBK 217F)

5 Slot	447.000 h
21 Slot	135.000 h

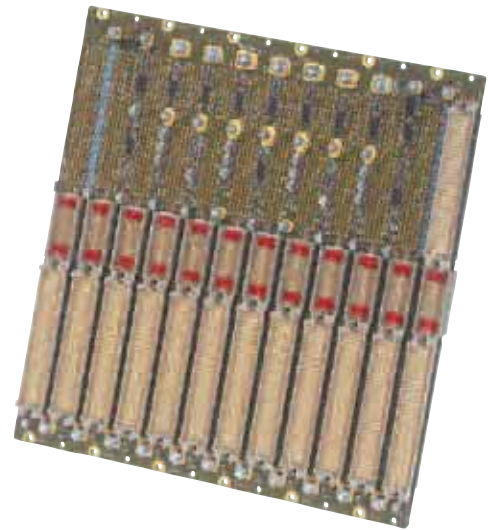

Pinout 12-way header (FCON):

	A B		
6	○ ○	A6: GND	B6: NC
5	○ ○	A5: GND	B5: +5V
4	○ ○	A4: ACF	B4: +3,3V
3	○ ○	A3: SysF	B3: +12V
2	○ ○	A2: SysR	B2: -12V
1	○ ○	A1: GND	B1: GND

ORDER CODE

32 20 - 2 - 0 60

option	code and description	note
Version	1 - without Po 2 - with Po	
Termination	2 - passive inboard	
Slots	02 to 21	
Daisy Chain	0 - automatic active	
Power connection	B - M3/M4 power bolts 3 - M8 power plate	>7 slot only
Shroud (1 J1, n J2)	6 - optional latchable	Ejectors not included in delivery
Contact plating	0 - Power inputs tinned DIN pins gold-plated class 2	

GENERAL

VME64x is an extension of the VME64 standard ANSIVITA 1-1994 and permits 64-bit data traffic. It defines a set of features that can be added to VME and VME64 boards, backplanes, and subracks. The major new features include expanded 160-pin P1/J1 and P2/J2 connectors, an optional 95-pin (2-mm hard metric P0/J0 connector) for more user-defined I/O, +3.3 V and auxiliary power voltage, plus more +5 V power. The VME64x system is downward-compatible, so that assemblies with 96-pin connectors to DIN 41612 can still be used.

Mechanical aspects of VME64x include support for EMC protection, ESD protection, solder side covers, an injector/extractor handle with locking, and board keying to specific subrack slots.

Applications:

- Industrial controls
- Military
- Medical
- Aerospace
- Transportation
- Telecom
- Simulation

VME protocols:

- Multiplexed block transfers (MBLT) with up to 80 Mbytes/s bandwidth
- 2eVME (2-Edge VME transfers); reduced handshaking with up to 160 Mbytes/s of bandwidth
- 2eSST (Source Synchronous Transfers); no handshaking with up to 320 Mbytes/s of bandwidth (special transceiver required)

PAPRAMETERS

CLIMATIC

- Operating temperature -40 °C to +85 °C
- Storage temperature -55 °C to +85 °C
- Climatic conditions IEC 68/1:25/085/21

MECHANICAL

- Flammability:
 - PCB: UL 94 V-0
 - Connectors: UL 94 V-0/-1
- Vibration:
 - According to DIN 41640 Part 15:
 - 10 Hz - 500 Hz 5 g rms
 - Impact (10 Impacts per axis x,y,z) 100 g, 6 ms
- Connectors DIN 41612, 160 way, class2, according to ANSI/VITA 1.7 - 2003 mechanical life 400 connection cycles
- Mechanical compliant to ANSI/IEEE 1101

ELECTRICAL

- Compliant to specification VME64x ANSI/VITA 1.1-1997
- Maximum data transfer rate 80 Mbyte/s for MBLT-protocol, 160 Mbyte/s for 2e-protocol, 320 Mbyte/s for 2eSST-protocol
- Single line impedance: 55 Ohm +/-10 %
- Passive termination (inboard)
- Basic current consumption: 1.5 A
- Current distribution

+5 V/GND	18 A/Slot
+3.3 V/GND	20 A/Slot
- Maximum voltage drop for + 5V and + 3.3 V < 40m V (at 9 A/Slot)

AVAILABLE SLOTS

No. of slot	2	3	4	5	6	7	8	9
PCB width (mm)	39.6	59.96	80.3	100.6	120.9	141.1	161.5	181.9
No. of slot	10	12	14	16	19	20	21	
PCB width (mm)	202.2	242.2	283.4	324.0	385.1	405.3	428.6	

VME64x 7U

FEATURES

- Automatic active Daisy Chain
- Configured for "high-power" applications (rails with connections M8 / M6 / M4)
- Ideal for plugging of Rear Transition Cards
- 10-layer construction
- Passive inboard termination (basic current consumption 1.5 A)
- Mounting holes for optional connection to Chassis GND
- Assembly with/without P0 connectors
- Characteristic impedance 55 Ohm +/-10 %
- Minimized crosstalk
- Effective decoupling of the DC voltages far beyond 1 GHz (act as EMI-filter)
- Mechanical compliant to ANSI /IEEE 1101
- PCB height 306.07 mm
- PCB thickness 4.5 mm
- Connector for status signals "FCON"
 - Part number of mating connector including 1.0 m cable, open end: 008-083
- Service life (MTBF, MIL-HDBK 217F)

5 Slot	447.000 h
21 Slot	135.000 h

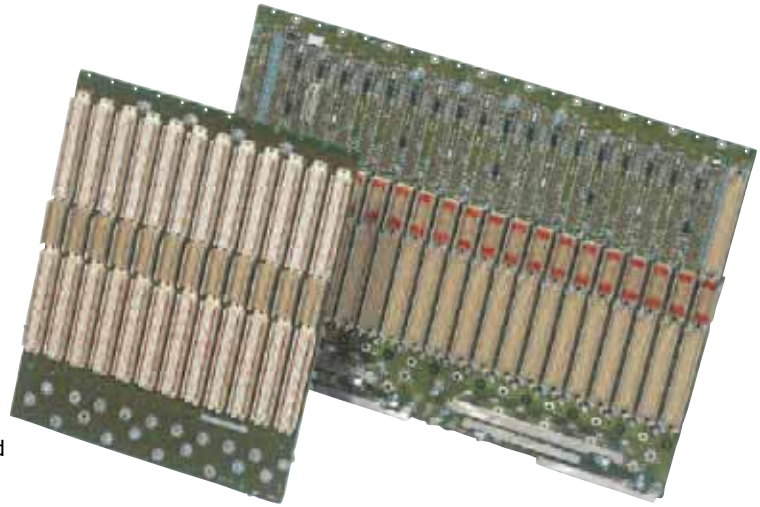

Pinout 12-way header (FCON):

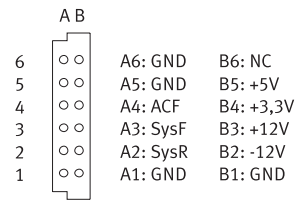

ORDER CODE

32 10 - 2 - 0060

option	code and description	note
Version	1 - without Po 2 - with Po	
Termination	2 - passive inboard	
Slots	02 to 21	
Daisy Chain	0 - automatic active	
Power connection	6 - power rails	M8, M6, M4 cabel lugs
Shroud (1 J1, n J2)	6 - optional latchable	Ejectors not included in delivery
Contact plating	0 - Power inputs tinned DIN pins gold-plated class 2	

GERNERAL

VME64x is an extension of the VME64 standard ANSI-VITA 1-1994 and permits 64-bit data traffic. It defines a set of features that can be added to VME and VME64 boards, backplanes, and subracks. The major new features include expanded 160-pin P1/J1 and P2/J2 connectors, an optional 95-pin (2-mm hard metric P0/J0 connector) for more user-defined I/O, +3.3 V and auxiliary power voltage, plus more +5 V power. The VME64x system is downward-compatible, so that assemblies with 96-pin connectors to DIN 41612 can still be used.

Mechanical aspects of VME64x include support for EMC protection, ESD protection, solder side covers, an injector/extractor handle with locking, and board keying to specific subrack slots.

Applications:

- Industrial controls
- Military
- Medical
- Aerospace
- Transportation
- Telecom
- Simulation

VME protocols:

- Multiplexed block transfers (MBLT) with up to 80 Mbytes/s bandwidth
- 2eVME (2-Edge VME transfers); reduced handshaking with up to 160 Mbytes/s of bandwidth
- 2eSST (Source Synchronous Transfers); no handshaking with up to 320 Mbytes/s of bandwidth (special transceiver required)

PAPRAMETERS

CLIMATIC

- Operating temperature -40 °C to +85 °C
- Storage temperature -55 °C to +85 °C
- Climatic conditions IEC 68/1:25/085/21

MECHANICAL

- Flammability:
 - PCB: UL 94 V-0
 - Connectors: UL 94 V-0/-1
- Vibration:
 - According to DIN 41640 Part 15:
 - 10 Hz - 500 Hz 5 g rms
 - Impact (10 Impacts per axis x,y,z) 100 g, 6 ms
- Connectors DIN 41612, 160 way, class2, according to ANSI/VITA 1.7 – 2003 mechanical life 400 connection cycles
- Mechanical compliant to ANSI/IEEE 1101

ELECTRICAL

- Compliant to specification VME64x ANSI/VITA 1.1-1997
- Maximum data transfer rate 80 Mbyte/s for MBLT-protocol, 160 Mbyte/s for 2e-protocol, 320 Mbyte/s for 2eSST-protocol
- Single line impedance: 55 Ohm +/-10 %
- Passive termination (inboard)
- Basic current consumption: 1.5 A
- Current distribution

+5 V/GND	18 A/Slot
+3.3 V/GND	20 A/Slot
- Maximum voltage drop for +5 V and + 3.3 V < 40 mV (at 9 A/Slot)

AVAILABLE SLOTS

No. of slot	3	5	7	9	10	12
PCB width (mm)	60	100.6	141.1	181.9	202.2	242.2

No. of slot	15	19	20	21
PCB width (mm)	303.7	385.1	405.3	428.6

VME64x Extenderboard

FEATURES

- 10-layer construction
- Assembly with/without P0 connectors
- Characteristic impedance 55 Ohm +/-10 %
- Handles for insertion/extraction of the daughter card
- Contact pin/jumper for each signal line
- PCB height 233.4 mm
- Extender depth 300.0 mm
(for use in 160 mm card cages)
- PCB thickness 3.2 mm
(with edges milled to 1.6mm for use in standard card guides)
- Access to GND, +3.3 V, +5 V, +12 V, -12 V via fastons

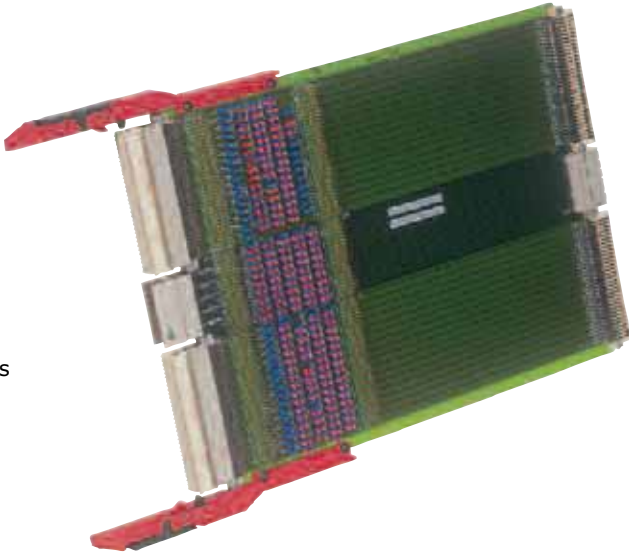

ORDER CODE

32 90 - 0000

option	code and description	note
Version	1 - without Po 2 - with Po	

VME64x is an extension of the VME64 standard ANSI-VITA 1-1994 and permits 64-bit data traffic. It defines a set of features that can be added to VME and VME64 boards, backplanes, and subracks. The major new features include expanded 160-pin P1/J1 and P2/J2 connectors, an optional 95-pin (2-mm hard metric P0/J0 connector) for more user-defined I/O, +3.3 V and auxiliary power voltage, plus more +5 V power. The VME64x system is downward-compatible, so that assemblies with 96-pin connectors to DIN 41612 can still be used. Mechanical aspects of VME64x include support for EMC protection, ESD protection, solder side covers, an injector/extractor handle with locking, and board keying to specific subrack slots.

Applications:

- Industrial controls
- Military
- Medical
- Aerospace
- Transportation
- Telecom
- Simulation

VME protocols:

- Multiplexed block transfers (MBLT) with up to 80 Mbytes/s bandwidth
- 2eVME (2-Edge VME transfers); reduced handshaking with up to 160 Mbytes/s of bandwidth
- 2eSST (Source Synchronous Transfers); no handshaking with up to 320 Mbytes/s of bandwidth (special transceiver required)

VME64X EXTENDERBOARD

The VME64x extender board supports daughter board testing. It is plugged into the backplane in the slot for the daughter board. The daughter board is plugged onto the extender board outside the card container, making it more easily accessible. All contacts with the backplane can be controlled individually by jumpers. Configured for 6U backplanes with 160 mm card depth, the extender board is available with connectors for J1/J2/J0 and for J1/J2. The test sector offers easy access, with tapping points right and left of the jumpers for all signal lines (and J0). GND, +3.3 V, +5 V, +12 V and -12 V are linked to power layers and each is accessible through a Faston connector.

VXibus Size C

FEATURES

- Automatic active Daisy Chain
- Configured for high-power applications (power bolts M4)
- Number of slots: 5, 7, 13
- Up to 7 slot 8-layer; 13 slot 10-layer construction
- Passive inboard termination (basic current consumption 1.5 A)
- Characteristic impedance 55 Ohm +/-10 %
- Effective decoupling to enhance dynamic current response
- Clock Skew <1ns
- Minimum GND-Shift
- Optimum separation of signal lines on inner layers
- PCB height 262.9 mm
- PCB thickness up to 7 Slot 3.2 mm; 13 slot 4.0 mm
- Connector for status signals (Fail, Reset, GND, +5 V)
 - Part number of mating connector including 1.0 m cable: 002-858
- Service life (MTBF according to MIL-HDBK 217F):

5 Slot	389 000 h
13 Slot	306 000 h

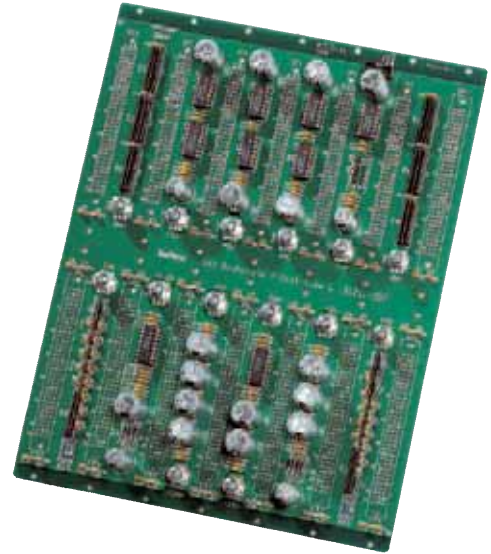

ORDER CODE

35211-2 - 00

option	code and description	note
Termination	2 - passive inboard	
Number of slots	05 to 13	
Daisy Chain	0 - automatic active	
Power connection	0 - 70A M4 Power bolts	

GENERAL

The VXIbus

The VXIbus system is based on the VMEbus and is designed for instrumentation applications. The logic protocols are VMEbus-compatible, so that standard VMEbus modules can be used. The P1 connector of the VXIbus is identical to the VMEbus. The differences lie in the VXIbus sub-system of the P2 and P3 planes. Voltages of ± 24 Vdc, -5.2 Vdc and -2 Vdc are provided in addition to the $+5$ Vdc and ± 12 Vdc voltages already available on the VMEbus. In addition, geographic address assignments have been introduced. The backplane also distributes a differential clock of 10 MHz on P2 and 100 MHz on P3, generated by the system controller board in slot 0. The daughter boards have been screened to meet EMC requirements.

This has meant a change in the geometrical dimensions compared with the VMEbus, with the slot spacing increased to 1.2" (0.8" on the VMEbus). Elma VXIbus backplanes have been fitted with the Automatic Active Daisy Chain and a special power supply system used in the Elma VMEbus *Classic* family.

Electrical parameters such as crosstalk, impedance, and GNDshift also meet the high specification of the VMEbus *Classic* family. Voltage fluctuations, in particular on the $+5$ V supply line, are kept very low, regardless of the power supply unit used, by integrating additional capacitors on the backplane.

PAPRAMETERS

CLIMATIC

- Operating temperature -40 °C to $+85$ °C
- Storage temperature -55 °C to $+85$ °C
- Climatic conditions category to IEC 68/1: 25/085/21

MECHANICAL

- Flammability:
 - PCB: UL 94 V-0
 - Connectors: UL 94 V-0/-1
- Vibration:
 - According to DIN 41640 Part 15: 10 Hz - 500Hz 5 g rms
 - Impact (10 Impacts per axis x,y,z) 100 g, 6 ms
- Connectors DIN 41612, C96, press-fit, quality class 2 with 400 connection cycles

ELECTRICAL

- Compliant to specification VXI Rev 2.0 8/1998
- Maximum data transfer rate 80 Mbyte/s for MBLT-protocol and 160 Mbyte/s for 2-e protocol
- Characteristic impedance: 55 Ohm
- Ohmic resistance of signal lines: < 60 mOhm/Slot
- Maximum voltage drop for $+5$ V: < 40 mV

AVAILABLE SLOTS

No. of slot	5	7	13
PCB width (mm)	144.78	205.74	388.62

Active Termination

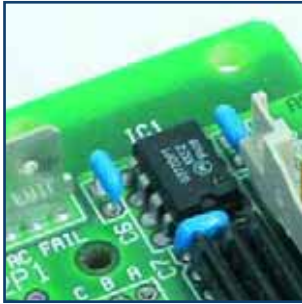

1- Active inboard (VME *Classic* backplanes only)

A voltage divider (330/470 Ω) produces the reference voltage for four operational amplifiers contained in two ICs. These op-amps, working as voltage followers, apply the required voltage of 2.94 V across 200 Ω resistors to the lines to be terminated. At the same time the resistors form the line termination.

Active termination is also suitable for tightly scaled power supply units, because no summing cross currents are formed (compared with passive termination) and only a small idling current flows.

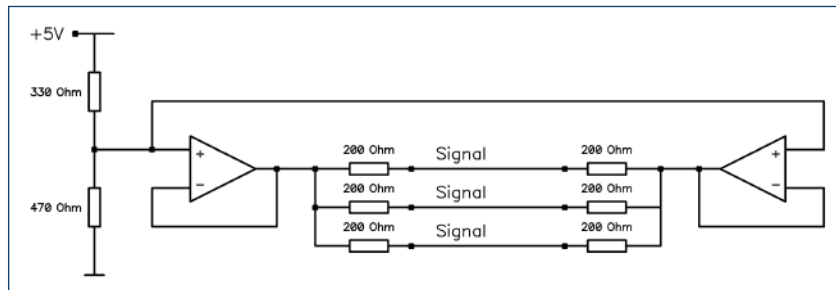

Passive Termination

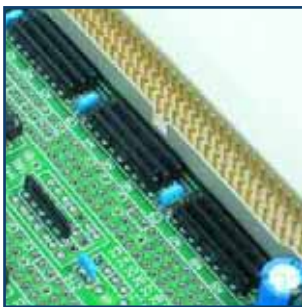

2- Passive inboard

Voltage dividers comprising resistor pairs (330 Ω to 470 Ω) produce a termination voltage of 2.94 V from the 5 Vdc supply voltage of the bus system and apply this to the lines. The parallel arrangement (with respect to high-frequencies) of the two resistors also terminates the line with a resistance of approx 200 Ω . This robust type of termination is well suited to, for example, power supply systems which need a base load for perfect operation. This base load is naturally supplied by the cross-currents which flow through the termination voltage dividers.

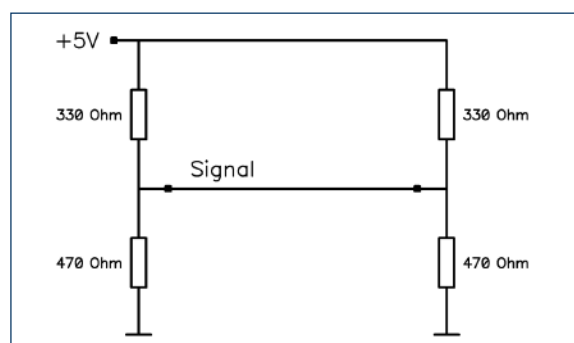

DAISY CHAIN

The VMEbus is designed to have a system controller in the first slot to coordinate and monitor the activities on the bus, and also to generate signals for a correct system start. Thus slot 1 has a special role in the VMEbus system.

If a slot is not occupied by a daughter board, then a link in the Daisy-Chain must be provided at this slot to ensure that boards further on the right are not disconnected from the interrupt procedure.

Automatic active



0- Automatic active

OR gates integrated in logic blocks automatically close the daisy-chain opened after removing the daughter board. Each IC houses four OR gates for passing on the active-LOW Daisy-Chain signals.

The resistor value R is chosen so that it can reliably pull the OUT line to low when the daughter board is removed, and yet not impede the output driver of the daughter board when it is plugged in.

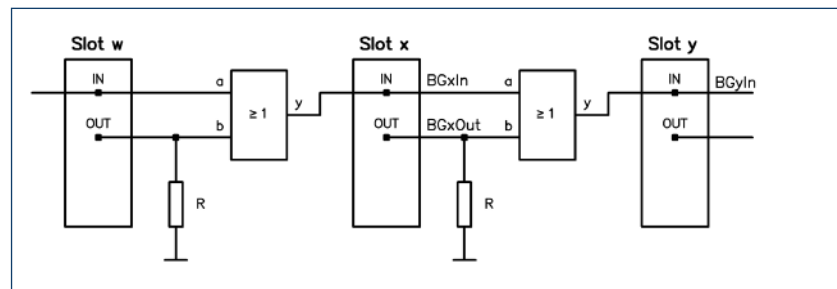

Jumper on both sides

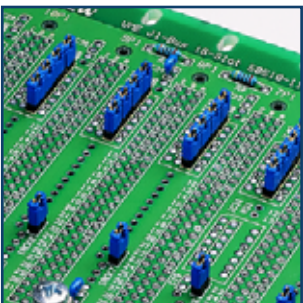

2- Jumper on both sides (VME Classic backplanes only)

The line pairs are linked by manually inserting five jumpers (per slot). The four BG line pairs form a jumper block, assigned to the respective slot, at the upper end of the J1 plane. Two jumper pins for the IACK line pair are located separately in the lower third of the J1 plane.

Available Options of VME *Classic* and VME64x backplanes

POWER CONNECTION VME J1, J2 AND MONOLITHIC *CLASSIC*

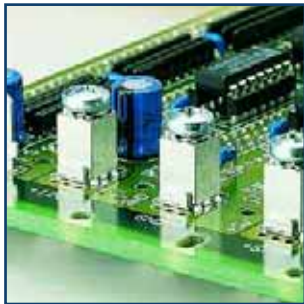

0 - Power bolts
M4 cable lug (70 A)



1 - Faston/M4 screw
2 x 6.3 x 0.8 (12 A)/
M4 cable lug (70 A)



6 - Fastons
6.3 x 0.8 (12 A)

POWER CONNECTION VME64X 6U



B - Power bolts
M3/M4 cable lug
(30 A/70 A)



3 - Power plate (> 7 slot)
M6/M8 cable lug (150 A)

POWER CONNECTION VME64X 7U

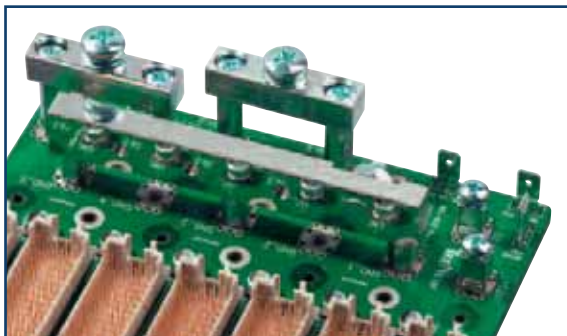

0 - Power rail
M4/M6/M8 cable lug (up to 150 A)

SHROUD VME J1, J2 AND MONOLITHIC CLASSIC

Rear I/O pin length: 13 mm



0 - Without latches



1- Optional latchable

Ejectors must be ordered separately.

Part number of ejectors: 017-815: 10x Type C (black)
017-816: 10x Type R (green)

SHROUD VME64X 6U AND VME64X 7U

Rear I/O pin length: 17 mm

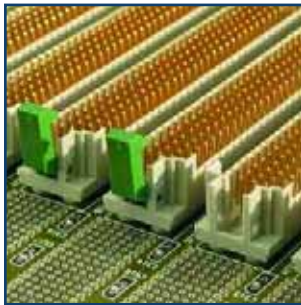

6 - Optional latchable

Only without P0; using cable connector on rear side

Ejectors must be ordered separately.

Part number of ejectors: 017-816: 10x Type R (green)

CONTACT PLATING

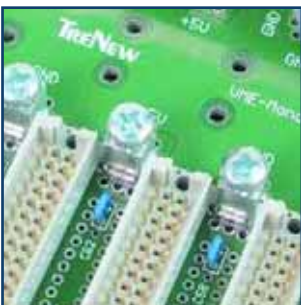

0 - Power Input tinned
DIN pins gold-plated class 2

Accessories for Elma Backplanes and System Platforms

SYSTEM MONITORING AND SHELF MANAGEMENT

Elma offers a wide range of monitoring products. Starting from low-cost multi-point power and temperature monitoring, through integrated fan and temperature control, to full AdvancedTCA dual-redundant shelf management. Depending on the model, support is offered for VME, VME64x, cPCI and ATCA architectures. Maximum flexibility and backplane slot availability is provided by cable-wired models, while the sophisticated 3U PICMG 2.x and ATCA cards may be plugged into the backplane for maximum convenience. All versions are available as individual products, or integrated into complete card-ready subsystems, custom configured and tested ready for system integration.



FORM FACTOR AND I/O ADAPTER

In addition to the standard backplane products we also offer a wide range of development backplanes and accessories. These backplanes can include power and ground only, full bus or no bus configurations. Accessories may consist of form factor adapters, extender boards, load cards, and slot by pass cards.

Overview of available products:

- 3U CompactPCI I/O Board
- 3U VME/VME64x I/O Board
- VME Adapter Board (160 to 220mm)
- VME64x Adapter Board (160 to 220mm)
- 1:1 bus



Overview of Elma Catalogs

ENCLOSURES & COMPONENTS

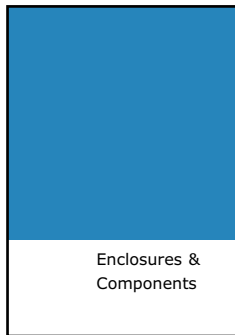

- Sub racks
- Enclosures
- Cabinets
- Front panels
- Injector/Ejector Handles
- Accessories
- Extrusions

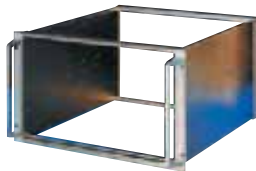

SYSTEM PLATFORMS

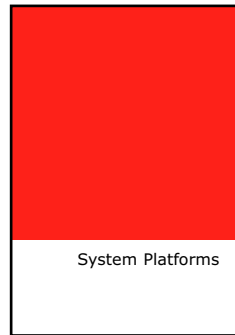

- Custom Solutions
- AdvancedTCA
- Switched Fabric
- CompactPCI
- VME, VME64x
- PXI, VXI
- COTS MIL
- Accessories



CABINETS

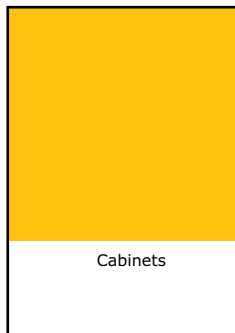

- Custom Solutions
- Commercial/Telecom
- Seismic
- EMC
- Military
- Electronic Desk Systems
- Instrument Cases
- Accessories



SWITCHES, KNOBS & LEDs

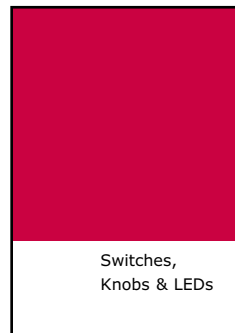

- Coded Switches
- Encoders
- Rotary Switches
- Keylock
- Audio Switches
- Collet Knobs and Accessories
- LED-Arrays

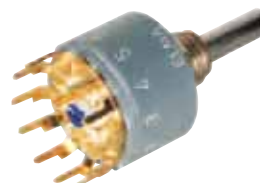



● Elma Companies

Subject to change without notice

SWITZERLAND

Elma Electronic AG

Hofstrasse 93, Postfach
CH-8620 Wetzikon
Phone +41 44 933 41 11
Fax CH +41 44 933 42 15
Fax Inter. +41 44 932 38 12
sales@elma.ch

UNITED STATES

Elma Electronic Inc.

44350 Grimmer Blvd.
Fremont, CA 94538
Phone +1 (510) 656-3400
Fax +1 (510) 656-3783
sales@elma.com

GERMANY

Elma Trenew Electronic GmbH

Stuttgarter Strasse 11
D-75179 Pforzheim
Phone +49 7231 97 34 0
Fax +49 7231 97 34 97
info@elma.de

CHINA

Elma Electronic China

Suite 605, Building 4
258 Jin Zang Road
20106 Shanghai, P.R. China
Phone +86 21 50318717
sales@elmachina.com

UNITED KINGDOM

Elma Electronic UK Ltd.

Premier Business Centre
Speedfields Park
GB-Fareham, Hampshire PO14 1TY
Phone +44 1 329 289 100
Fax +44 1 329 289 101
sales@elma-electronic.co.uk

FRANCE

Elma Electronic France SA

ZA du Buisson Rond
F-38460 Villemoirieu
Phone +33 4 37 06 21 10
Fax +33 4 37 06 21 19
sales@elma-electronic.fr

ISRAEL

Elma Electronic Israel Ltd.

9 Ben Zion Galis St.
IL-I.Z. Sgula Petach Tikva 49277
Phone +972 3 930 5025
Fax +972 3 931 3134
sales@elma.co.il

ROMANIA

Elma Electronic Romania SRL

Str. Maltopol 16
RO-011047 Bucuresti
Phone +40 21 3 10 79 98
Fax +40 21 3 10 79 92
info@elma.ro

www.elma.com

Your local solution partner: