

# AT8020 User's Guide

**Advanced TCA®**

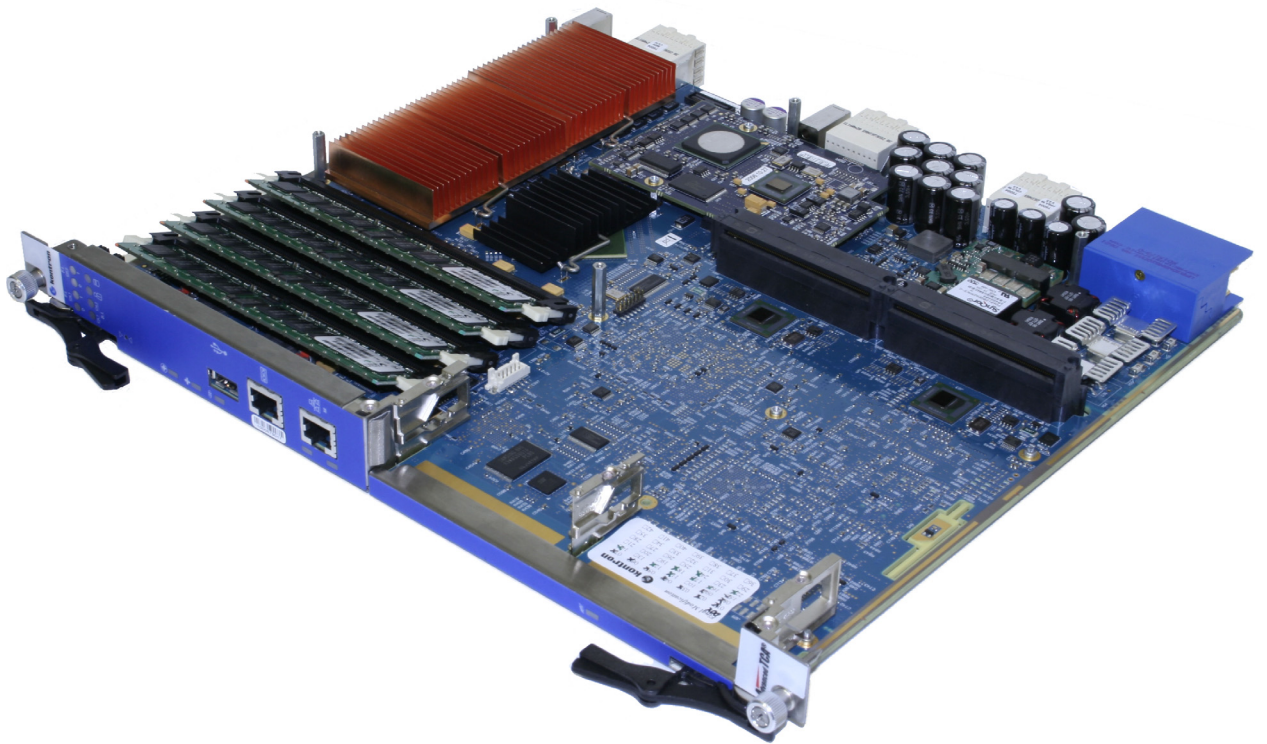

Document Revision 1.1  
Ref. : 1016-2638/ May 2008

# Customer Service

## Contact Information:

### Kontron Canada, Inc.

616 Curé-Boivin  
Boisbriand, Québec, Canada  
J7G 2A7  
Tel: (450) 437-5682  
(800) 354-4223  
Fax: (450) 437-8053  
E-mail: [support@ca.kontron.com](mailto:support@ca.kontron.com)

### Kontron Modular Computer GMBH

Sudetenstrasse 7  
87600 Kaufbeuren  
Germany  
+49 (0) 8341 803 333  
+49 (0) 8341 803 339  
[support-kom@kontron.com](mailto:support-kom@kontron.com)

Visit our site at: [www.kontron.com](http://www.kontron.com)

© 2008 Kontron, an International Corporation. All rights reserved.

The information in this user's guide is provided for reference only. Kontron does not assume any liability arising out of the application or use of the information or products described herein. This user's guide may contain or reference information and products protected by copyrights or patents and does not convey any license under the patent rights of Kontron, nor the rights of others.

Kontron is a registered trademark of Kontron. All trademarks, registered trademarks, and trade names used in this user's guide are the property of their respective owners. All rights reserved. Printed in Canada. This user's guide contains information proprietary to Kontron. Customers may reprint and use this user's guide in other publications. Customers may alter this user's guide and publish it only after they remove the Kontron name, cover, and logo.

Kontron reserves the right to make changes without notice in product or component design as warranted by evolution in user needs or progress in engineering or manufacturing technology. Changes that affect the operation of the unit will be documented in the next revision of this user's guide.

# Table of Contents

<i>Safety instructions</i> .....	<i>vi</i>
Before You Begin .....	vi
Preventing Electrostatic Discharge .....	vii
<i>Preface</i> .....	<i>viii</i>
How to Use This Guide .....	viii
Customer Comments .....	ix
Advisory Conventions .....	ix
Unpacking .....	x
Powering Up the System .....	x
Adapter Cables .....	x
Storing Boards .....	x
Regulatory Compliance Statements .....	xi
Limited Warranty .....	xii
<b>1. Product Description</b> .....	<b>1</b>
1.1 Product Overview .....	1
1.2 What's Included .....	1
1.3 Board Specifications .....	2
1.4 Compliance .....	4
1.5 Hot-Plug Capability .....	4
1.6 Interfacing with the Environment .....	5
1.6.1 RTM (rear transition module) .....	5
1.6.2 AMC Mezzanine .....	5
<b>2. Board Features</b> .....	<b>6</b>
2.1 Block Diagram .....	6
2.2 System Core .....	7
2.2.1 Processors .....	7
2.2.2 Intel E7520 Chipset .....	8
2.3 USB 2.0 Interfaces .....	9
2.4 Onboard Flash Drive .....	10
2.5 Serial Ports .....	10
2.5.1 Serial Port 1 (J5) .....	10
2.5.2 Serial Port 2 .....	11

<b>2.6</b>	<b>Real Time Clock &amp; NVRAM</b> .....	<b>11</b>
<b>2.7</b>	<b>Ethernet Interfaces</b> .....	<b>11</b>
2.7.1	i82551QM Ethernet Management .....	11
2.7.2	i82571EB Base Interface .....	12
2.7.3	i82571EB Fabric Interface Port 0 .....	12
2.7.4	i82571EB Fabric Interface Port 1 (Daughter Card) .....	12
<b>2.8</b>	<b>SAS (Daughter Card)</b> .....	<b>13</b>
<b>2.9</b>	<b>Crosspoint Switches</b> .....	<b>13</b>
<b>2.10</b>	<b>AMC Mezzanines</b> .....	<b>13</b>
2.10.1	AMC Ports Mapping AMC B1 .....	14
2.10.2	AMC Ports Mapping AMC B2 .....	15
<b>2.11</b>	<b>Redundant BIOS Flash</b> .....	<b>15</b>
<b>2.12</b>	<b>Redundant IPMC Flash &amp; FWUM</b> .....	<b>16</b>
<b>2.13</b>	<b>FPGA</b> .....	<b>16</b>
<b>2.14</b>	<b>Telecom Clock Option</b> .....	<b>17</b>
<b>2.15</b>	<b>Hardware Management</b> .....	<b>17</b>
2.15.1	Hardware Management Overview .....	17
2.15.2	Sensor Data Record (SDR) .....	18
2.15.3	IPMI Sensors .....	19
2.15.4	Events supported .....	24
2.15.5	Field Replaceable Unit (FRU) Information .....	26
2.15.6	IPMI Over LAN (IOL) support .....	37
2.15.7	Serial Over LAN support (SOL) .....	39
2.15.8	IPMC Firmware Code .....	39
2.15.9	IPMC Firmware Upgrade Procedure .....	39
2.15.10	Updating AT8020 BIOS .....	40
2.15.11	IPMI commands set on AT8020 .....	41
2.15.12	OEM IPMI Commands .....	47
2.15.13	Hot-Swap Process .....	49
<b>2.16</b>	<b>Debugging Features</b> .....	<b>52</b>
2.16.1	Lamp Test .....	52
<b>3.</b>	<b><i>Installing the Board</i></b> .....	<b>53</b>
<b>3.1</b>	<b>Setting Jumpers</b> .....	<b>53</b>
3.1.1	Jumper Description .....	53
3.1.2	Setting Jumper & Locations .....	54
<b>3.2</b>	<b>Processor</b> .....	<b>55</b>
<b>3.3</b>	<b>Memory</b> .....	<b>55</b>
3.3.1	Installing Memory .....	57

<b>3.4</b>	<b>Onboard Interconnectivity and Indicators</b> .....	<b>58</b>
3.4.1	Onboard Connectors and Headers .....	58
3.4.2	Front Plate Symbol Chart .....	58
<b>3.5</b>	<b>Board Hot Swap and Installation</b> .....	<b>59</b>
3.5.1	Installing the Card in the Chassis .....	59
3.5.2	Removing the Board .....	59
3.5.3	Installing an AMC .....	60
3.5.4	Removing an AMC .....	60
3.5.5	Installing a RTM .....	60
3.5.6	Removing a RTM .....	60
<b>4.</b>	<b>Building an ATCA System</b> .....	<b>61</b>
<b>4.1</b>	<b>Building an ATCA System</b> .....	<b>61</b>
4.1.1	Backplane .....	61
4.1.2	Rear-Panel I/O .....	62
4.1.3	External Storage Devices .....	62
4.1.4	Power Supply .....	62
4.1.5	Mechanical Keying and Alignment .....	62
<b>5.</b>	<b>Software Setup</b> .....	<b>63</b>
<b>5.1</b>	<b>AMI BIOS Setup Program</b> .....	<b>63</b>
5.1.1	Accessing the BIOS Setup Utility .....	63
5.1.2	Menu Bar .....	65
5.1.3	Main Menu .....	67
5.1.4	Advances Menu .....	67
5.1.5	Security Menu .....	80
5.1.6	Boot Menu .....	80
5.1.7	System Management Menu .....	81
5.1.8	Exit Menu .....	85
<b>5.2</b>	<b>Boot Utilities</b> .....	<b>86</b>
5.2.1	Pressing <Del> (or <F4> from a Console Redirection terminal) .....	86
5.2.2	Pressing <F11> (or <F3> from a Console Redirection terminal) .....	86
5.2.3	BOOT Menu POP-UP .....	86
<b>5.3</b>	<b>Console Redirection (VT100 Mode)</b> .....	<b>87</b>
5.3.1	Requirements .....	87
5.3.2	Running Without a Terminal .....	87
5.3.3	ANSI and VT100 Keystroke Mapping .....	88
5.3.4	VT-UTF8 Keystroke Mapping .....	88

5.4	<b>Installing Drivers</b> .....	<b>89</b>
5.4.1	SAS Drivers .....	89
5.4.2	Ethernet Drivers .....	89
5.4.3	Other Drivers.....	89
<b>A.</b>	<b><i>Memory &amp; I/O Maps</i></b> .....	<b><i>A-1</i></b>
A.1	Memory Mapping.....	A-1
A.2	I/O Mapping .....	A-2
A.3	PCI IDSEL and Device numbers.....	A-3
<b>B.</b>	<b><i>Kontron Extension Registers</i></b> .....	<b><i>B-1</i></b>
B.1	FPGA/CPLD Registers Definition .....	B-1
B.2	Sossaman Addressing Space.....	B-2
<b>C.</b>	<b><i>Connector Pinouts</i></b> .....	<b><i>C-1</i></b>
C.1	Connectors and Headers Summary.....	C-1
C.2	ATCA I/O RTM Connector (J7) .....	C-2
C.3	USB Port (J13) .....	C-2
C.4	Serial Port(J14) .....	C-3
C.5	Telco Clock(J17) .....	C-3
C.6	AMC B1 & AMC B2 (J20 & J23) .....	C-4
C.7	ATCA I/O ATCA 3.1 (J21).....	C-5
C.8	Power (P10) .....	C-6
<b>D.</b>	<b><i>BIOS Setup Error Codes</i></b> .....	<b><i>D-1</i></b>
D.1	Bootblock Initialization Code Checkpoints .....	D-1
D.2	Bootblock Recovery Code Checkpoints.....	2
D.3	POST Code Checkpoints.....	D-2
D.4	DIM Code Checkpoints .....	D-5
D.5	ACPI Runtime Checkpoints .....	D-6
D.6	Memory Initialization ERROR Code .....	D-6
<b>E.</b>	<b><i>Software Update</i></b> .....	<b><i>E-1</i></b>
E.1	Flash BIOS Update Procedure .....	E-1
E.2	IPMC Firmware Update Procedure .....	E-1
<b>F.</b>	<b><i>Getting Help</i></b> .....	<b><i>F-1</i></b>
F.1	Returning Defective Merchandise .....	F-2
F.2	When Returning a Unit.....	F-3

# Safety instructions

## Before You Begin

Before handling the board, read the instructions and safety guidelines on the following pages to prevent damage to the product and to ensure your own personal safety. Refer to the "Advisories" section in the Preface for advisory conventions used in this user's guide, including the distinction between Warnings, Cautions, Important Notes, and Notes.

- Always use caution when handling/operating the computer. Only qualified, experienced, authorized electronics service personnel should access the interior of the computer. The power supplies produce high voltages and energy hazards, which can cause bodily harm.
- Use extreme caution when installing or removing components. Refer to the installation instructions in this user's guide for precautions and procedures. If you have any questions, please contact Kontron Technical Support



### WARNING

High voltages are present inside the chassis when the unit's power cord is plugged into an electrical outlet. Turn off system power, turn off the power supply, and then disconnect the power cord from its source before removing the chassis cover. Turning off the system power switch does not remove power to components.



# Preventing Electrostatic Discharge

Static electricity can harm system boards. Perform service at an ESD workstation and follow proper ESD procedure to reduce the risk of damage to components. Kontron strongly encourages you to follow proper ESD procedure, which can include wrist straps and smocks, when servicing equipment.

Take the following steps to prevent damage from electrostatic discharge (ESD):

- When unpacking a static-sensitive component from its shipping carton, do not remove the component's antistatic packing material until you are ready to install the component in a computer. Just before unwrapping the antistatic packaging, be sure you are at an ESD workstation or at least properly grounded. This is required to discharge any static electricity that may have built up on your body.
- When transporting a sensitive component, first place it in an antistatic container or packaging.
- Handle all sensitive components at an ESD workstation. If possible, use antistatic floor pads and workbench pads.
- Handle components and boards with care. Don't touch the components or contacts on a board. Hold a board preferably by its metal mounting bracket, shield or frame; if not possible, hold it by its edges.
- Do not handle or store system boards near strong electrostatic, electromagnetic, magnetic, or radioactive fields.
- When you want to remove the protective foil (if present), make sure you are properly grounded and that you touch (with bare hand or static dissipative gloves) the metallic front plate, shield or frame of the board.



---

**CAUTION**

Removing the protective foil from the top and bottom cover might create static.  
When you remove those protections, make sure you follow the proper ESD procedure.



# Preface

## How to Use This Guide

This user's guide is designed to be used as step-by-step instructions for installation, and as a reference for operation, troubleshooting, and upgrades.

You can find the latest release of this User's Guide at:

<http://www.kontron.com> or at: <ftp://ftp.kontron.ca/support/>

For the circuits, descriptions and tables indicated, Kontron assumes no responsibility as far as patents or other rights of third parties are concerned.

The following is a summary of chapter contents:









- Chapter 1, Product Description
- Chapter 2, Board Features
- Chapter 3, Installing the board
- Chapter 4, Building an ATCA System
- Chapter 5, Software Setup
- Appendix A, Memory & I/O Maps
- Appendix B, Connector Pinout
- Appendix C, BIOS Setup Error Codes
- Appendix D, Software Update
- Appendix E, Getting Help

# Customer Comments

If you have any difficulties using this user's guide, discover an error, or just want to provide some feedback, please send a message to: [Tech.Writer@ca.kontron.com](mailto:Tech.Writer@ca.kontron.com). Detail any errors you find. We will correct the errors or problems as soon as possible and post the revised user's guide on our Web site. Thank you.

## Advisory Conventions

Seven types of advisories are used throughout the user guides to provide helpful information or to alert you to the potential for hardware damage or personal injury. They are Note, Signal Paths, Jumpers Settings, BIOS Settings, Software Usage, Cautions, and Warnings. The following is an example of each type of advisory. Use caution when servicing electrical components.

	<b>Note:</b> Indicate information that is important for you to know.	
	<b>Signal Path:</b> Indicate the places where you can find the signal on the board.	
	<b>Jumper Settings:</b> Indicate the jumpers that are related to this sections.	
	<b>BIOS Settings:</b> Indicate where you can set this option in the BIOS.	
	<b>Software Usage:</b> Indicates how you can access this feature through software.	
	<b>CAUTION</b>	
	<b>WARNING</b>	
	Indicate potential damage to hardware and tells you how to avoid the problem.	
	Indicates potential for bodily harm and tells you how to avoid the problem.	

**Disclaimer:** We have tried to identify all situations that may pose a warning or a caution condition in this user's guide. However, Kontron does not claim to have covered all situations that might require the use of a Caution or a Warning.

# Unpacking

Follow these recommendations while unpacking:

- Remove all items from the box. If any items listed on the purchase order are missing, notify Kontron customer service immediately.
- Inspect the product for damage. If there is damage, notify Kontron customer service immediately.
- Save the box and packing material for possible future shipment.

# Powering Up the System

Before any installation or setup, ensure that the board is unplugged from power sources or subsystems.

If you encounter a problem, verify the following items:

- Make sure that all connectors are properly connected.
- Verify your boot devices.
- If the system does not start properly, try booting without any other I/O peripherals attached, including AMC adapters.

Make sure your system provides the minimum DC voltages required at the board's slot, especially if DC power is carried by cables.

If you are still not able to get your board running, contact our Technical Support for assistance.

# Adapter Cables

Because adapter cables come from various manufacturers, pinouts can differ. The direct crimp design offered by Kontron allows the simplest cable assembly. All cables are available from Kontron Sales Department.

# Storing Boards

Electronic boards are sensitive devices. Do not handle or store device near strong electrostatic, electromagnetic, magnetic or radioactive fields.

# Regulatory Compliance Statements

## *FCC Compliance Statement for Class B Devices*

This equipment has been tested and found to comply with the limits for a Class B digital device, pursuant to Part 15 of the FCC Rules. These limits are designed to provide reasonable protection against harmful interference in a residential installation. This equipment generated, uses and can radiate radio frequency energy and, if not installed and used in accordance with the instructions may cause harmful interference to radio communications. However, there is no guarantee that interference will not occur in a particular installation. If this equipment does cause harmful interference to radio or television reception, which can be determined by turning the equipment off and on, the user is encouraged to try to correct the interference by one or more of the following measures:

- Reorient or relocate the receiving antenna.
- Increase the separation between the equipment and receiver.
- Connect the equipment into an outlet on a circuit different from that to which the receiver is connected.
- Consult the dealer or an experience radio/TV technician for help.



---

**WARNING**

This is a Class B product. If not installed in a properly shielded enclosure and used in accordance with this User's Guide, this product may cause radio interference in which case users may need to take additional measures at their own expense.

---



## *CB Certification*

This product has a CB Certificate and test report to IEC 60950-1.

## *CE Certification*

The product(s) described in this user's guide complies with all applicable European Union (CE) directives if it has a CE marking. For computer systems to remain CE compliant, only CE-compliant parts may be used. Maintaining CE compliance also requires proper cable and cabling techniques. Although Kontron offers accessories, the customer must ensure that these products are installed with proper shielding to maintain CE compliance. Kontron does not offer engineering services for designing cabling systems. In addition, Kontron will not retest or recertify systems or components that have been reconfigured by customers.

# Limited Warranty

Kontron grants the original purchaser of Kontron's products a TWO YEAR LIMITED HARDWARE WARRANTY as described in the following. However, no other warranties that may be granted or implied by anyone on behalf of Kontron are valid unless the consumer has the express written consent of Kontron.

Kontron warrants their own products, excluding software, to be free from manufacturing and material defects for a period of 24 consecutive months from the date of purchase. This warranty is not transferable nor extendible to cover any other users or long-term storage of the product. It does not cover products which have been modified, altered or repaired by any other party than Kontron or their authorized agents. Furthermore, any product which has been, or is suspected of being damaged as a result of negligence, improper use, incorrect handling, servicing or maintenance, or which has been damaged as a result of excessive current/voltage or temperature, or which has had its serial number(s), any other markings or parts thereof altered, defaced or removed will also be excluded from this warranty.

If the customer's eligibility for warranty has not been voided, in the event of any claim, he may return the product at the earliest possible convenience to the original place of purchase, together with a copy of the original document of purchase, a full description of the application the product is used on and a description of the defect. Pack the product in such a way as to ensure safe transportation (see our safety instructions).

Kontron provides for repair or replacement of any part, assembly or sub-assembly at their own discretion, or to refund the original cost of purchase, if appropriate. In the event of repair, refunding or replacement of any part, the ownership of the removed or replaced parts reverts to Kontron, and the remaining part of the original guarantee, or any new guarantee to cover the repaired or replaced items, will be transferred to cover the new or repaired items. Any extensions to the original guarantee are considered gestures of goodwill, and will be defined in the "Repair Report" issued by Kontron with the repaired or replaced item.

Kontron will not accept liability for any further claims resulting directly or indirectly from any warranty claim, other than the above specified repair, replacement or refunding. In particular, all claims for damage to any system or process in which the product was employed, or any loss incurred as a result of the product not functioning at any given time, are excluded. The extent of Kontron liability to the customer shall not exceed the original purchase price of the item for which the claim exists.

Kontron issues no warranty or representation, either explicit or implicit, with respect to its products reliability, fitness, quality, marketability or ability to fulfil any particular application or purpose. As a result, the products are sold "as is," and the responsibility to ensure their suitability for any given task remains that of the purchaser. In no event will Kontron be liable for direct, indirect or consequential damages resulting from the use of our hardware or software products, or documentation, even if Kontron were advised of the possibility of such claims prior to the purchase of the product or during any period since the date of its purchase.

Please remember that no Kontron employee, dealer or agent is authorized to make any modification or addition to the above specified terms, either verbally or in any other form, written or electronically transmitted, without the company's consent.

# 1. Product Description

## 1.1 Product Overview

The new Kontron AT8020 AdvancedTCA processor board features one or two Intel® Dual-Core Xeon® processors and support for two AdvancedMC modules. The result is an open modular processing platform that will increase the number of deployments of AdvancedTCA solutions at the heart of every compute intensive mobile-IMS network element — from the transcoding of live multimedia mobile content on a Multimedia Resource Function Processor (MRFP) to concurrent processing of subscriber data on Home Subscriber Locator (HLR) systems.

## 1.2 What's Included

This board is shipped with the following items:

- One AT8020 board
- One CD-ROM containing documentations and drivers
- Cables that have been ordered
- AMCs gap fillers

If any item is missing or damaged, contact the supplier.

## 1.3 Board Specifications

Features	Description
Processors	<ul style="list-style-type: none"> <li>One or Two Dual-Core Intel Xeon LV Processors 2.0GHz</li> <li>Passive heatsink(s)</li> </ul>
Cache Memory	<ul style="list-style-type: none"> <li>32KB L1 instruction and 32KB L1 data cache dedicated for each core.</li> <li>2MB L2 cache on each processor chip shared by both cores.</li> </ul>
Chipset	<ul style="list-style-type: none"> <li>North Bridge: Intel E7520</li> <li>South Bridge: Intel 6300ESB</li> </ul>
Bus Interface	<ul style="list-style-type: none"> <li>CPUs Front Side bus at 667 MHz, 64-bit data, 36-bit address</li> <li>Memory bus at 400 MHz, 144-bit data (2 channel)</li> <li>Six onboard PCI-Express x4</li> </ul>
Expansion Slot	<ul style="list-style-type: none"> <li>2 Mid-size AdvancedMC bays AMC.1 Type 4 compliant – x4 PCI Express, AMC.2 Type E2 compliant – 2 X1000Base-BX Ports, AMC.3 compliant – dual port SAS/SATA</li> </ul>
System Memory	<ul style="list-style-type: none"> <li>Up to 16 GB on 4x240-pin latching DDR-2 400MHz SDRAM (PC2-3200)</li> <li>ECC support, support S4EC/D4ED when using x4 SDRAM devices</li> <li>2 DDR-2 channels</li> </ul>
Flash Memory	<ul style="list-style-type: none"> <li>Two redundant 1MB BIOS (Field software upgradeable)</li> <li>Roll back functionality controlled by IPMC</li> </ul>
Storage	<ul style="list-style-type: none"> <li>4 ports SAS available through each AdvancedMC modules or through Rear I/O</li> <li>One 2GBytes onboard flash drive</li> </ul>
Connectors	<ul style="list-style-type: none"> <li>Front Panel: Serial (RJ-45), USB, Ethernet Management Port (RJ-45)</li> </ul>
Board Specifications	<ul style="list-style-type: none"> <li>PICMG 3.0</li> <li>PICMG AMC.0 (Compatible)</li> <li>PICMG AMC.1</li> <li>PICMG AMC.2</li> <li>PICMG AMC.3</li> </ul>
BIOS Features	<ul style="list-style-type: none"> <li>AMI BIOS</li> <li>Save CMOS in NVRAM option</li> <li>Boot from gigabit Ethernet (Base and Fabric interfaces)</li> <li>Boot from Ethernet Management port</li> <li>Boot from SAS</li> <li>Boot from USB 2.0 (Floppy, CD-ROM, Hard Disk)</li> <li>Auto configuration and extended setup</li> <li>Diskless, Keyboard less, and battery less operation extensions</li> <li>System and LAN BIOS shadowing</li> <li>HDD S.M.A.R.T. support</li> <li>Advanced Configuration and Power Interface (ACPI 1.0, 2.0 &amp; 3.0) (advanced thermal management such as overheat alarm and auto slow down)</li> <li>Console redirection to serial port (VT100) with CMOS setup access</li> <li>Field updateable BIOS</li> <li>Event (SERR, PERR, correctable/uncorrectable ECC, POST errors, PCI-Express) log support to IPMC</li> </ul>

Features	Description
IPMI Features	<ul style="list-style-type: none"> <li>Management Controller is compatible to PICMG 3.0, AMC.0 and IPMI v1.5 rev 1.1.</li> <li>Management Controller is run time field reprogrammable without payload impact.</li> <li>Robust fail safe reprogramming implementation (which includes two firmware images) that can perform automatic or manual rollback if a problem occurs during critical reprogramming phase.</li> <li>Remote upgrade capability from all IPMI interfaces (CPU Host Interface/IPMB-0/LAN).</li> <li>Management Controller self test which can detect failure under its code integrity and trigger an automatic rollback.</li> <li>Initiation of a Host CPU reboot on a redundant BIOS image base on a BIOS-IPMC handshake result.</li> <li>Fast interrupt driven SMS host interface compliant to IPMI-KCS v1.5 rev 1.1</li> <li>Serial Over LAN (SOL) redirection of the Host CPU serial controller traffic to enable asynchronous serial-based OS and pre-OS communication via standard RMCP LAN application through the Management Controller.</li> <li>Standard Management Controller message bridging to AMC via IPMB-L</li> <li>Management Controller support standard PCI Hot Plug for PCI-Express AMC.</li> <li>Management Controller can initiate standard graceful OS shutdown via ACPI support.</li> </ul>
Supervisory	<ul style="list-style-type: none"> <li>Supports a system management interface via an IPMI V1.5 compliant controller</li> <li>Watchdog for BIOS execution and OS loading (through IPMI and FPGA watchdogs)</li> <li>Hardware system monitor (voltages, temperature), CPU temperature monitor / alarm; board temperature sensor, power failure through IPMC</li> </ul>
OS Compatibility	<ul style="list-style-type: none"> <li>Red Hat Enterprise Linux V.4</li> </ul>
Power Requirements	200W maximum including AMC modules. Additional 25W maximum for RTM
Environmental Temperature*	Operating: 0-55°C/32-131°F with 30CFM airflow Storage and Transit: -40 to +70°C/-40 to 158°F
Environmental Humidity*	Operating: 15% to 90% @55°C/131°F non-condensing Storage and Transit: 5% to 95% @ 40°C/104°F non-condensing
Environmental Altitude*	Operating: 4,000 m / 13,123 ft Storage and Transit: 15,000 m / 49,212 ft
Environmental Shock*	Operating: 30G, half-sine 11ms, each axis Storage and Transit: Bellcore GR-63-CORE Section 4.3
Environmental Vibration*	Operating: 1.0G, 5-500Hz each axis Storage and Transit: 2.0G, 5-50Hz; 3.0G, 50-500Hz each axis
Reliability	<ul style="list-style-type: none"> <li>MTBF: &gt; 120 000 hours @ 40 C / 104 F (Telcordia SR-332, Issue 1)</li> <li>Whole board protected by active breaker</li> <li>USB voltage protected by an active breakers</li> </ul>
Safety / EMC	Meet or exceed: <ul style="list-style-type: none"> <li>Safety: UL 60950-1; CSA C22.2 No 60950-1-03; EN 60950-1:2001; IEC60950-1</li> <li>EMI/EMC: FCC 47 CFR Part 15, Class B; CE Mark to EN55022/EN55024/EN300386</li> </ul>
Warranty	Two years limited warranty

\* Designed to meet or exceed

## 1.4 Compliance

This product conforms to the following specifications:

- PICMG3.0R2.0 (Advanced TCA core specification)
- PICMG3.1R1.0 (Ethernet/Fiber Channel over Advanced TCA)
- Compatible to AMC.0 R2.0 (Advanced mezzanine card base specification)
- AMC.1 R1.0 (Advance mezzanine card PCI-Express)

## 1.5 Hot-Plug Capability

The AT8020 supports Full Hot Plug capability as per PICMG3.0R1.0. It can be removed from or installed in the system while it is on (without powering-down the system). Please refer to the PICMG3.0R1.0 specification for additional details.

## 1.6 Interfacing with the Environment

### 1.6.1 RTM (rear transition module)

The RTM8020 is a single slot (6HP) ATCA Rear Transition Module. This module provides additional connectivity for AT8020 CPU front blade and complies to:

- PICMG3.0 R2.0 ECN002 - Advanced Telecommunication Computing Architecture
- SAS1R10 - Serial Attached SCSI - 1.1 Revision 10. (SAS-1.1)
- SFF-8470 (T10 Technical Committee and SCSI Trade Association)

### 1.6.2 AMC Mezzanine

The AT8020 has two AMC bays. Using a mezzanine allows to add storage or I/O not provided on board.

See Kontron's mezzanine offering for additional I/O capabilities.

Both AMC sites provide the same feature set. Each slot provides a AMC.1 type 8SE2. This mean that the following signalling are supported:

- PCI-Express X4 on AMC port 4-7
- PCI-Express clock on FCLKA
- Gigabit Ethernet on AMC port 0 and 1
- Telco clock on CLK1
- SAS on AMC port 2 and 3

# 2. Board Features

## 2.1 Block Diagram

### AT8020 (T5004) ATCA Dual Core Xeon LV (Sossaman), 2x AMC

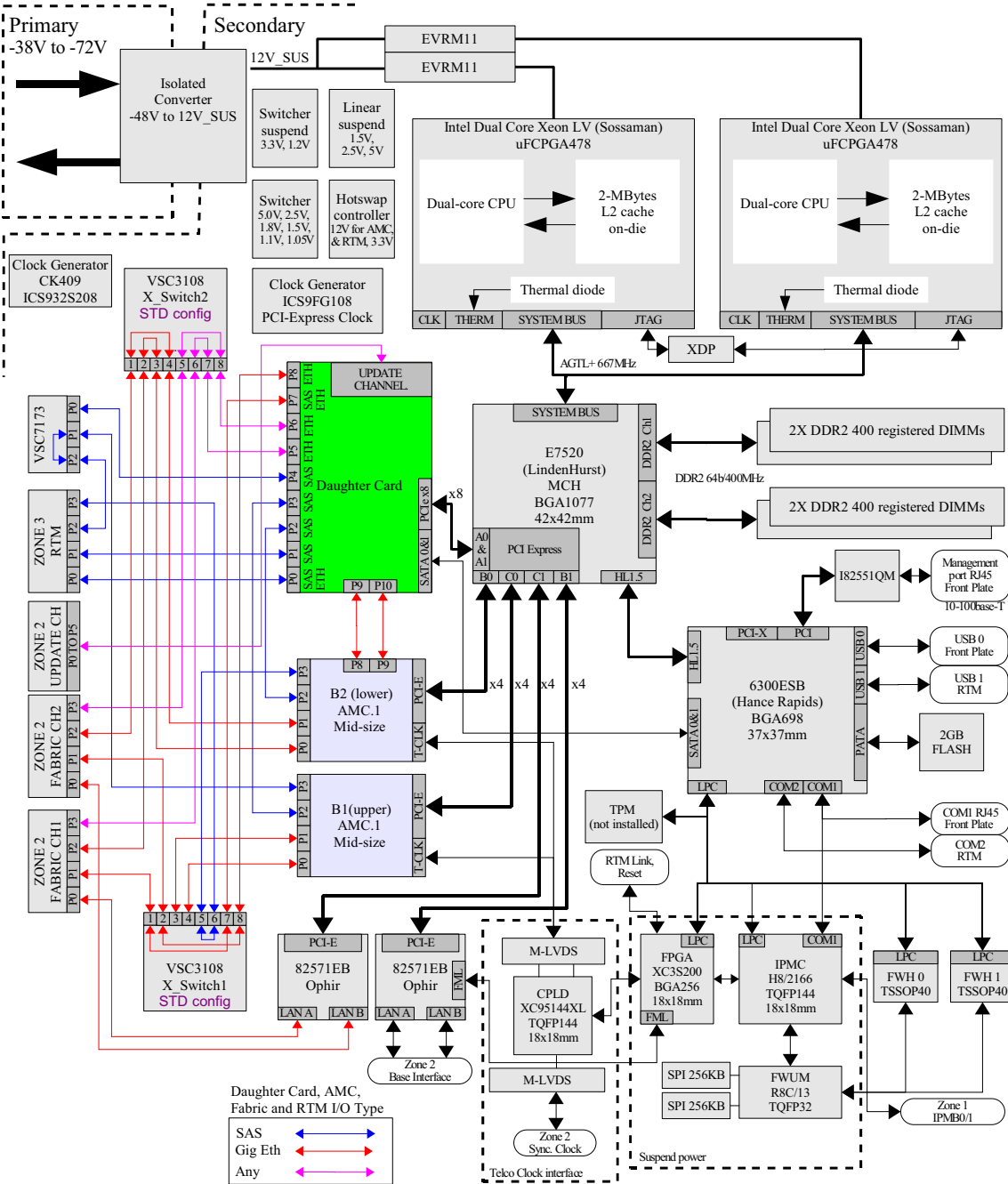

## 2.2 System Core

### 2.2.1 Processors

The Dual-Core Intel® Xeon® processor LV 2.0 GHz is a member of Intel's growing product line of multi-core processors. This processor combines the benefits of dual-core with dual-processor capabilities providing four high-performance cores per platform. While incorporating advanced processor technology, this dual-core processor remains software-compatible with previous 32-bit Intel® Architecture processors. Product highlights are listed below.

- Two complete execution cores in one processor package provide advancements in simultaneous computing such as multi-threaded applications and multi-tasking environments.
- 667 MHz front-side bus (FSB). Combined with dual-core processing, this supports up to four simultaneous threads on the system.
- Enhanced Intel SpeedStep® technology allows a system to dynamically adjust processor voltage and core frequency, decreasing average power consumption and average heat production.
- Intel Smart Cache Design allows two execution cores to share 2 MB of L2 cache, reducing FSB traffic and enhancing system responsiveness.
- Intel Advanced Thermal Manager supports new digital temperature sensors and thermal monitors on each execution core to enhance thermal monitoring accuracy.
- Streaming SIMD Extensions 3 (SSE3) provides significant performance enhancement for multi-media applications. Additional instructions designed to improve thread synchronization, complex arithmetic, graphics, and video encoding.
- Fully code compatible with existing Intel architecture-based 32-bit application software.
- FSB address, data, and response parity protection provides a key reliability and data integrity feature for the communications, storage, and other embedded market segments.
- Enhanced 36-bit memory addressing supports up to 16 GB of DDR2 memory, when paired with the Intel E7520 chipset.

## 2.2.2 Intel E7520 Chipset

The Intel E7520 Memory Controller Hub (MCH) includes PCI Express serial I/O technology and DDR2 memory technology to help increase I/O bandwidth and reduce system latency for data-intensive applications. It is the central hub for all data passing among the core system elements, including processors, memory, PCI Express I/O, and legacy I/O subsystems. Product Highlights are listed below.

### 2.2.2.1 *Memory*

Intel E7520 chipset-based platforms is designed to support single- or dual-channel DDR2-400 memory (up to 16 GB). The memory subsystem interface to the MCH is dual channel, supporting two registered DIMMs per channel for a total system bandwidth of up to 6.4 GB/s.

### 2.2.2.2 *PCI Express*

For demanding I/O and networking applications, PCI Express interfaces attach a variety of I/O components and adapters directly to the Intel E7520 MCH at throughput speeds of up to 10 GB/s on each x4 interface, allowing I/O to keep pace with the rest of the platform. The MCH has three x8 PCI Express interfaces which can each be bifurcated into two x4 interfaces for additional configuration flexibility.

### 2.2.2.3 *Intel 6300ESB I/O Controller Hub*

Available as the I/O controller hub for legacy I/O support, the Intel 6300ESB I/O Controller Hub (ICH) attaches directly to the MCH through the Intel Hub Interface 1.5 connection. Four Hi-Speed USB 2.0 ports allow easy I/O connection while offering improved bandwidth compared to USB 1.1 devices. The Intel 6300ESB ICH incorporates the functionality of two 16550 compatible serial ports and of two 8259 interrupt controllers that provide system interrupts for the ISA compatible interrupts.

## 2.3 USB 2.0 Interfaces

USB features include:

- Capability to daisy chain as many as 127 devices per interface
- Fast bi-directional
- Isochronous/asynchronous interface
- 480 MBPS transfer rate
- Standardization of peripheral interfaces into a single format
- Retro compatible with USB 1.1 devices

USB supports Plug and Play and hot-swapping operations (OS level). These features allow USB devices to be automatically attached, configured and detached, without reboot or running setup.

Pin	Signal
1	VCC
2	DATA-
3	DATA+
4	GND



### Signal Path:

The USB Port is available through the front plate (J13) and through the RTM connector.

## 2.4 Onboard Flash Drive

There is a 2GBytes onboard flash drive on the AT8020. This drive is connected through the Primary IDE logical interface and is set in master mode. This drive support ATA/IDE protocol with up to PIO Mode4 and Multi-word DMA Mode-2 interface.

## 2.5 Serial Ports

Two serial ports are provided on board for asynchronous serial communications. They support 8-byte FIFO buffers for transfer rates from 50bps to 115Kbps.

Each serial port is specified as follows:

Designation	Communication Mode	Output Path
Serial Port A (COM1)	RS-232	Front Plate Serial port or IPMI over LAN
Serial Port B (COM2)	RS-232	RTM

UART registers are individually addressable and fully programmable.

### 2.5.1 Serial Port 1 (J5)

Serial Port A is buffered directly for RS-232 operation. Signals include the complete signal set for handshaking, modem control, interrupt generation, and data transfer. Serial Port A (COM1) is automatically switched to the front plate when a terminal is connected in the front panel RJ-45 connector. When assigned as Serial Port A, the port is 100% compatible with the IBM-AT serial port in RS-232 mode.

Pin	Signal
1	RTS
2	DTR
3	TX#
4	GND/DCD
5	GND
6	RX#
7	DSR
8	CTS



#### Note:

Standard product uses a RJ-45 8 pins connector. RI (ring indicator) and DCD (data carrier detect) signals are not available.

The pinout is a custom one, it is not the same as RS-232D TIA/EIA-561.



#### Signal Path:

The Serial Port A signals are always available in front access through J14 or through the IPMC.



#### BIOS Settings:

There is no BIOS settings, but Serial Port A is fixed to the following address: 3F8h IRQ 4

## 2.5.2 Serial Port 2

Serial Port 2 is connected to the RTM.



### BIOS Settings:

There is no BIOS settings, but Serial Port B is fixed to the following address: 2F8h IRQ 3

## 2.6 Real Time Clock & NVRAM

The AT8020 is a battery less board. The real time clock and non-volatile RAM integrated in the 6300ESB ICH are powered by the main supply when available or by a double layer SuperCap when the main power is absent. The SuperCap will keep the real time clock running for a minimum of 2 hours.

Although it is possible to save the CMOS setup in NVRAM (or CMOS RAM), the default configuration saves the setup in flash. So, when the AT8020 is unpowered for a long time, only the time will be lost.

## 2.7 Ethernet Interfaces

The AT8020 has a dual 1000 Base-T (supports also 10 Base-T and 100 Base-TX) interfaces to the base interface and two dual 1000 Base-BX interfaces to the fabric interface. Three (two onboard and one on the daughter card) 82571EB dual gigabit Ethernet controllers provide those interfaces. The AT8020 also has a 10/100 management port connected with a i82551QM controller.

### 2.7.1 i82551QM Ethernet Management

The management port is implemented with a i82551QM Ethernet chip. It supports a 10/100 Base-T connection with autonegotiation.

The i82551QM features high performance with TCP/IP and UDP/IP checksum offloading for IPv4 and IPv6, packet filtering, and jumbo frame up to 16K. See [www.intel.com](http://www.intel.com) for additional details on the i82551QM.

The AT8020 has boot from LAN capability (PXE) on this port. This option must be enabled from the BIOS Setup Program.



### BIOS Settings:

Advanced --> Expansion ROM Configuration --> Ethernet 82551QM Expansion ROM



### Signal Path:

The Ethernet Management RJ45 connector is on the faceplate.

## 2.7.2 i82571EB Base Interface

The ATCA base interface is implemented with a i82571EB twin-gigabit Ethernet controller. It supports 10/100/1000 Base-T connections with autonegotiation to the base interface channel 1 and 2.

The i82571EB features high performance with TCP/IP and UDP/IP checksum offloading for IPv4 and IPv6, packet filtering, and jumbo frame up to 16K. See [www.intel.com](http://www.intel.com) for additional details on the i82571.

The AT8020 has boot from LAN capability (PXE) on those ports. This option must be enabled from the BIOS Setup Program.



### BIOS Settings:

Advanced --> Expansion ROM Configuration --> Ethernet BI Expansion ROM

## 2.7.3 i82571EB Fabric Interface Port 0

A second i82571EB is used. Both ethernet ports are routed to the fabric channel port 0. The first one is connected to channel 1 and the second is connected to channel 2.

The i82571EB features high performance with TCP/IP and UDP/IP checksum offloading for IPv4 and IPv6, packet filtering, and jumbo frame up to 16K. See [www.intel.com](http://www.intel.com) for additional details on the i82571EB.

The AT8020 has boot from LAN capability (PXE) on those ports. This option must be enabled from the BIOS Setup Program.



### BIOS Settings:

Advanced --> Expansion ROM Configuration --> Ethernet FI Expansion ROM

## 2.7.4 i82571EB Fabric Interface Port 1 (Daughter Card)

A third i82571EB is used in various configurations through a daughter card. Both ethernet ports are routed to the fabric channel 1 and channel 2 of port 1. The first one is connected to channel 1 and the second is connected to channel 2.

The i82571EB features high performance with TCP/IP and UDP/IP checksum offloading for IPv4 and IPv6, packet filtering, and jumbo frame up to 16K. See [www.intel.com](http://www.intel.com) for additional details on the i82571EB.

The AT8020 has boot from LAN capability (PXE) on those ports. This option must be enabled from the BIOS Setup Program.



### BIOS Settings:

Advanced --> Expansion ROM Configuration --> Ethernet MEZ Expansion ROM

## 2.8 SAS (Daughter Card)

SAS interface is provided through a daughter card. Both AMC slots have the same SAS connectivity. For a particular AMC, there is one link from the SAS controller to the AMC (for a AMC based SAS HDD) and a second link is connected directly from the AMC to the RTM. The SAS controller used on the daughter card is the LSISAS1064e from LSI. SAS HDD can be used either with one alone CPU (no connection to the RTM) or as a two CPU; two HDD redundant pair. In this case both CPUs have access to both HDDs via the RTM and cabling.

## 2.9 Crosspoint Switches

The crosspoint switches are multiport devices that allow connecting any inputs to any outputs. Two 8x8 crosspoint switches are used (Vitesse VSC3108). Those switches are protocol-agnostic and can carry SERDES type signals at up to 6.5Gb/s NRZ data. This means that any compatible endpoint can be connected. The connectivity is controlled by the IPMI e-keying. After the initialisation, the configuration is static.

The crosspoint switches also act as a buffer between the AMC ports 0-1 and the fabric interface to properly configure the I/O depending on daughter card that is installed.

## 2.10 AMC Mezzanines

Two AMC sites are available. Characteristics of each AMC are as follow:

- Type B+
- Support mid-size single width mechanical format
- PCI-Express X4 with reference clock on AMC FCLKA
- Fully compliant PCI hot-swap support
- Port 0 and 1 connected to crosspoint switches (LAN)
- Provision for telecom clocks on TCLKA-B-C
- Both AMC slots have a SAS link to the daughter card and an other SAS link to the RTM connector.
- Compliant to AMC.1, AMC.2 and AMC.3; compatible to AMC.0 R2.0.
- The electric power budget for AMC is limited to 42W/slot, 60W total by the IPMI.

As per AMC.1 R2.0, the carrier board (AT8020) is required to provide PCI-E 100MHz reference clock to the AMC on FCLKA. However, modules are not required to use it. Kontron recommends using AMC-Express modules that use the reference clock on FCLKA. If the module makes its own reference clock, then the spread spectrum of the AT8020 clock synthesizer needs to be disabled in the BIOS setup, otherwise the behavior of the PCI-Express link will be erratic at best.

**Note:**

All electromagnetic compatibility tests have been done with spread spectrum. Disabling the spread spectrum can complicate EMC.

The telco clock signal allows the AT8020 to provide clock to the AMC on TCLKA. For possible clock frequency and connection with the backplane, refer to section Telecom Clock Option.

## 2.10.1 AMC Ports Mapping AMC B1

Ports	Connection type	Standard	Other possibilities
TCLKA	Telco clock*	J20 CLK2 RX	J20 CLK1 <b>OR</b> J20 CLK2 TX <b>OR</b> J20 CLK3
TCLKB	Telco clock*	None	J20 CLK1 <b>OR</b> J20 CLK2 TX <b>OR</b> J20 CLK3
TCLKC	Telco clock*	None	J20 CLK1 <b>OR</b> J20 CLK2 TX <b>OR</b> J20 CLK3
TCLKD	Telco clock*	N/C	N/C
FCLKA	Fabric clock	100MHz PCIe CLK	None
0	Ethernet	None	**Fabric CH1 P1 <b>OR</b> Fabric CH2 P1 <b>OR</b> Daughter P7 <b>OR</b> Daughter P8
1	Ethernet	None	**Fabric CH1 P1 <b>OR</b> Fabric CH2 P1 <b>OR</b> Daughter P7 <b>OR</b> Daughter P8
2	SAS/SATA	Daughter card P3	None
3	SAS/SATA	None	RTM P2
4	PCIe	MCH	None
5	PCIe	MCH	None
6	PCIe	MCH	None
7	PCIe	MCH	None
8	N/C	N/C	N/C
9	N/C	N/C	N/C
10	N/C	N/C	N/C
11	N/C	N/C	N/C
12	N/C	N/C	N/C
13	N/C	N/C	N/C
14	N/C	N/C	N/C
15	N/C	N/C	N/C
16	N/C	N/C	N/C
17	N/C	N/C	N/C
18	N/C	N/C	N/C
19	N/C	N/C	N/C
20	N/C	N/C	N/C

\* Notice that for each possible Telco clock connection, it is hardware wise possible (software may need to be implemented) to transmit or receive clock.

\*\* Using that option with the T5511B daughter card would mean the daughter card's 82571EB Ethernet ports wouldn't be connected to the Fabric Channel 1 P1 and Channel 2 P1

## 2.10.2 AMC Ports Mapping AMC B2

Ports	Connection type	Standard	Other possibilities
TCLKA	Telco clock*	J20 CLK2 RX	J20 CLK1 <b>OR</b> J20 CLK2 TX <b>OR</b> J20 CLK3
TCLKB	Telco clock*	None	J20 CLK1 <b>OR</b> J20 CLK2 TX <b>OR</b> J20 CLK3
TCLKC	Telco clock*	None	J20 CLK1 <b>OR</b> J20 CLK2 TX <b>OR</b> J20 CLK3
TCLKD	Telco clock*	N/C	N/C
FCLKA	Fabric Clock	100MHz PCIe CLK	None
0	Ethernet	Fabric CH1 P2	Fabric CH2 P2 <b>OR</b> Fabric CH1 P3 <b>OR</b> Fabric CH2 P3
1	Ethernet	Fabric CH2 P2	Fabric CH1 P2 <b>OR</b> Fabric CH2 P3 <b>OR</b> Fabric CH1 P3
2	SAS/SATA	Daughter card P2	None
3	SAS/SATA	None	RTM Port3
4	PCIe	MCH	None
5	PCIe	MCH	None
6	PCIe	MCH	None
7	PCIe	MCH	None
8	Ethernet	None	**Daughter card P9 through Daughter card P7 can be connected to Fabric Channel 1 P1 <b>OR</b> to Channel 2 P1 <b>OR</b> to AMC B1 P0 <b>OR</b> to AMC B1 P1
9	Ethernet	None	**Daughter card P10 through Daughter card P8 can be connected to Fabric Channel 1 P1 <b>OR</b> to Channel 2 P1 <b>OR</b> to AMC B1 P0 <b>OR</b> to AMC B1 P1
10	N/C	None	None
11	N/C	None	None
12	N/C	None	None
13	N/C	None	None
14	N/C	None	None
15	Serial port	None	Serial port to RTM
16	N/C	None	None
17	N/C	None	None
18	N/C	None	None
19	N/C	None	None
20	N/C	None	None

\* Notice that for each possible Telco clock connection, it is hardware wise possible (software may need to be implemented) to transmit or receive clock.

\*\* Using that option with the T5511B daughter card would mean the daughter card's 82571EB Ethernet ports wouldn't be connected to the Fabric Channel 1 P1 and Channel 2 P1

## 2.11 Redundant BIOS Flash

Two BIOS flashes (firmware hub or FWH) are present on the AT8020. If a BIOS update corrupts a flash and prevents the CPU from completing the boot sequence, the IPMC will force a reboot from the other BIOS flash.



### Note:

Since the CMOS setup is saved in flash, this will also restore the previous BIOS setup.

## 2.12 Redundant IPMC Flash & FWUM

The IPMC runs a firmware from its internal 512KB flash. It is programmed by an other microcontroller named FWUM (Firmware Update Manager). The FWUM keeps the last two copies of the IPMC firmware in dedicated flash memories. The FWUM acts as a watchdog to the IPMC and can rollback a firmware update in the IPMC in case of problems.

The FWUM itself is a microcontroller with internal flash. The FWUM firmware is field updatable possibly with payload impact however.

**Note:**

The IPMC and the FWUM have an internal hardware watchdog.

---

## 2.13 FPGA

The FPGA has many functions. One of them is to act as a companion chip to the IPMC. The states of all the critical signals controlled by the IPMC are memorized in the FPGA and are preserved while the IPMC firmware is being updated.

The FPGA is a RAM-based chip that is preloaded from a separate flash memory at power-up. Two such flash memory devices are provided. One that can only be programmed in factory and an other one that can be updated in the field. The factory flash can selected by inserting jumper JP1 pins 13-14. Field updates require a power cycle of the board.

The appropriate procedure to upgrade the FPGA will be provided with the update code when needed.

## 2.14 Telecom Clock Option

This board provides an elaborate set of Telecom clocks (also called Telco clocks), which allows several configurations. It can generate its own clock, which can be routed to the backplane or to an AMC. It can also receive the signal from the backplane and route it to an AMC and vice versa.

The circuit is made of Multipoint-Low-Voltage Differential Signaling (MLVDS) buffers, a Complex Programmable Logic Device (CPLD) and a Digital Phase Locked Loop (DPLL). It could generate or receive clocks in the backplane, as specified in the PICMG3.0 specification, for a variety of SONET/SDH standard frequencies ranging from 2 kHz to 19.44 MHz. These clocks could be either driven or received on the following signals: CLK1A+/-, CLK1B+/-, CLK2A+/-, CLK2B+/-, CLK3A+/-, CLK3B+/- . The same goes for the telecom clocks interfaces provided by the AMC.0 specification. These clocks are defined as TCLKA+/-, TCLKB+/- and TCLKC+/- . No clock can be used on TCLKD+/- signal.

Interrupts could also be generated based on a PICMG3.0 or AMC.0 clock. For a detailed solution, please consult your local technical support.

## 2.15 Hardware Management

### 2.15.1 Hardware Management Overview

The main processors communicate with the Intelligent Management Controller (IPMC) using the Keyboard Controller Style (KCS) system management interface. BIOS uses SMM interface. The base address of the LPC interface for SMS is 0xCA2 and 0xCA4 for SMM operation. Besides that, the BIOS is able to communicate with the IPMC for POST error logging purposes and fault resilient purposes.

The memory subsystem of the IPMC consists of an integrated flash memory to hold the IPMC operation code and integrated RAM for data. The field replacement unit (FRU) inventory information is stored in the nonvolatile memory on an EEPROM connected via a local I2C interface to the IPMC microcontroller. It is possible to store up to 4 KBytes within the FRU inventory information. Event generation over IPMB bus to reach the ShMc SEL ensures that 'post-mortem' logging information is available even if the main processor becomes disabled. The IPMC also implements it's own SEL that can store up to 1023 events.

The IPMC provides six I2C bus connections. Two are used as the redundant IPMB bus connections to the backplane. One is used for IPMB-L bus with AMC modules. One is used for LAN connections for the IPMI over LAN support. An other one is also used by the monitoring chip and the last one is for local EEPROM storage.

If an IPMB bus fault or IPMC failure occurs, IPMB isolators are used to switch and isolate the backplane/system IPMB bus from the faulted SBC board. Where possible, the IPMC will isolate the failure line and will use the other bus to re-establish system management communication to report the fault.

The onboard DC voltages, currents, and temperature are monitored by the IPMC microcontroller device. The IPMC will log an event into the ShMc SEL if any thresholds are exceeded.

To increase the reliability of the AT8020 SBC management subsystem, an external watchdog supervisor only for the IPMC is implemented. The IPMC must strobe the external watchdog at two-second intervals to ensure continuity of operation of the board's management subsystem. If the IPMC ceases to strobe the watchdog

supervisor, the watchdog isolates the IPMC from the IPMBs and resets the IPMC. The watchdog supervisor does not reset the payload power; the restart of the IPMC will not affect the payload and will restore the previous Hot Swap state and power level negotiated with the ShMc. The watchdog timeout expires after six seconds if strobes are not generated. The external watchdog supervisor is not configurable and must not be confused with the IPMI v1.5 watchdog timer commands.

This external watchdog of the IPMC is implemented in a second microcontroller. This microcontroller is responsible to monitor the IPMC and to manage IPMC fail-safe firmware upgrade process. The name of this second microcontroller is the Firmware Upgrade Manager (FWUM). The FWUM can handle two Firmware codes that are stored in two external SEEPROM memories. If a failure occurs during firmware upgrade, the FWUM will automatically rollback to the redundant IPMC firmware image.

## 2.15.2 Sensor Data Record (SDR)

Every sensor on the baseboard is associated with a Sensor Data Record (SDR). Sensor Data Records contain information about the sensors identification such as sensor type, sensor name, sensor unit. SDR also contain the configuration of a specific sensor such as threshold/hysteresis, event generation capabilities that specifies sensor behavior. Some field of the sensor SDR are configurable through IPMI v1.5 command and are set to built-in initial value. Finally one field which is the sensor owner must reflect the baseboard addresses that allow the ShMc to identify the owner of the SDR when it is scanned from the satellite management controller and saved within the ShMc SDR repository.

The AT8020 management controller is set up as a satellite management controller (SMC). It does support sensor devices, and use the IPMI dynamic sensor population feature of IPMI v1.5 to merge the hot swapped AMC and RTM sensors with the AT8020 sensors population. The usual way the ShMc is informed about an AMC insertion is through the AMC carrier Hot Swap sensor. However, to remain compliant to IPMI v1.5, the IPMC updates the population change indicator timestamp accessible through the Get Device SDR Info command. All SDRs can be queried using Device SDR commands to the firmware. Baseboard sensors that have been implemented are listed below.

**Note:**

The SDR is based on version: SDR #38.

---

## 2.15.3 IPMI Sensors

IPMI sensor ID	Sensor Name	Description
0	FRU0 Hot Swap	ATCA Board FRU Hot Swap Sensor
1	FRU1 Hot Swap	AMC Bay B1 Hot Swap sensor
2	FRU2 Hot Swap	AMC Bay B2 Hot Swap sensor
3	FRU3 Hot Swap	RTM Hot swap sensor
4	FRU0 Reconfig	Sensor Population Change on Carrier
5	Temp Air Inlet	Upper Non-Critical event: 45 deg C. Upper Critical event: 50 deg C.
6	Temp CPU 0 Vcore	Upper Non-Critical event: 85 deg C. Upper Critical event: 90 deg C. Upper Non-Recoverable: 105 deg C.
7	Temp CPU0	Temperature of CPU-0 Upper Non-Critical event: 85 deg C. Upper Critical event: 90 deg C. Upper Non-Recoverable: 100 deg C.
8	Temp CPU1	Temperature of CPU-1 Upper Non-Critical event: 85 deg C. Upper Critical event: 90 deg C. Upper Non-Recoverable: 100 deg C.
9	Temp DIMMA Inlet	Upper Critical event: 60 deg C. Upper Non-Critical event:55 deg C.
10	Temp DIMMB Inlet	Upper Critical event: 60 deg C. Upper Non-Critical event:55 deg C.
11	Temp DIMM Outlet	Upper Critical event: 68 deg C. Upper Non-Critical event:62 deg C.
12	Temp MCH	Upper Critical event: 85 deg C. Upper Non-Critical event:80 deg C.
13	Temp MCH Inlet	Upper Critical event: 80 deg C. Upper Non-Critical event:75 deg C.
14	Temp LAN BIntf	Upper Critical event: 90 deg C. Upper Non-Critical event:85 deg C.
15	Temp LAN FIntf	Upper Critical event: 90 deg C. Upper Non-Critical event:85 deg C.
16	Temp Mez Area	Upper Critical event: 80 deg C. Upper Non-Critical event:75 deg C.
17	Power Good	Current power status
18	Power Good Event	Power status event that occurred since the last power on or reset.
19	VCORE 0	CPU 0 Core Voltage Upper Critical event: +1.377V Upper Non-Critical event: +0.783V
20	VCORE 1	CPU 1 Core Voltage Upper Critical event: +1.377V Upper Non-Critical event: +0.783V

IPMI sensor ID	Sensor Name	Description
22	Vcc -48V	Voltage on -48v board input power supply Upper Critical event: -75V Lower Critical Event: -37.8V Hysteresis:1.25V
23	Vcc +12V	Voltage on 12v board power supply Upper Critical event: 12.60v (5%) Lower Critical Event: 11.40v (5%) Hysteresis: 0.180v (1.5%)
24	Vcc +5V	Voltage on 5v board power supply Upper Critical event: 5.25v (5%) Lower Critical Event: 4.75v (5%) Hysteresis: 0.075v (1.5%)
25	Vcc +5V SUS	Voltage on 5v suspend (management) board power supply Upper Critical event: 5.25v (5%) Lower Critical Event: 4.75v (5%) Hysteresis: 0.075v (1.5%)
26	Vcc +3.3V	Voltage on 3.3v board power supply Upper Critical event: 3.47v (5%) Lower Critical Event: 3.13v (5%) Hysteresis: 0.050v (1.5%)
27	Vcc +3.3V SUS	Voltage on 3.3v suspend (management) board power supply Upper Critical event: 3.47v (5%) Lower Critical Event: 3.13v (5%) Hysteresis: 0.050v (1.5%)
28	Vcc +2.5V	Voltage on 2.5v board power supply Upper Critical event: 2.63v (5%) Lower Critical Event: 2.37v (5%) Hysteresis: 0.038v (1.5%)
29	Vcc Ref +2.5V	Voltage on 2.5v board power supply Upper Critical event: 2.63v (5%) Lower Critical Event: 2.37v (5%) Hysteresis: 0.038v (1.5%)
30	Vcc +2.5V SUS	Voltage on 2.5v suspend (management) board power supply Upper Critical event: 2.63v (5%) Lower Critical Event: 2.37v (5%) Hysteresis: 0.038v (1.5%)
31	Vcc +1.8V	Voltage on 1.8v suspend (management) board power supply Upper Critical event: 1.89v (5%) Lower Critical Event: 1.71v (5%) Hysteresis: 0.027v (1.5%)
32	Vcc +1.5V	Voltage on 1.5v board power supply Upper Critical event: 1.58v (10%) Lower Critical Event: 1.42v (10%) Hysteresis: 0.025v (1.5%)
33	Vcc +1.5V SUS	Voltage on 1.5v suspend (management) board power supply Upper Critical event: 1.58v (10%) Lower Critical Event: 1.42v (10%) Hysteresis: 0.025v (1.5%)

IPMI sensor ID	Sensor Name	Description
34	Vcc +1.2V SUS	Voltage on 1.2v suspend (management) board power supply Upper Critical event: 1.26v (10%) Lower Critical Event: 1.14v (10%) Hysteresis: 0.018v (1.5%)
35	Vcc +1.1V SUS	Voltage on 1.2v board power supply Upper Critical event: 1.16v (10%) Lower Critical Event: 1.04v (10%) Hysteresis: 0.017v (1.5%)
36	Vcc VTT DDR	Voltage on the memory (1.05) Upper Critical event: 1.11v (10%) Lower Critical Event: 0.99v (10%) Hysteresis: 0.016v (1.5%)
37	-48V A Pres-Fuse	Fuse presence and fault detection -48 V on supply A
38	-48V B Pres-Fuse	Fuse presence and fault detection -48 V on supply B
39	FRU0 Power	FRU 0 Power consumption in watts Upper Critical : (0xBC)+180.480 Upper Non-Critical : (0xAC)+165.120
40	FRU1 Power	FRU 1 Power consumption in watts Upper Critical : (0x40) +30.080 Upper Non-Critical : (0x3A) +27.260
41	FRU2 Power	FRU 2 Power consumption in watts Upper Critical : (0x40) +30.080 Upper Non-Critical : (0x3A) +27.260
42	FRU3 Power	FRU 3 Power consumption in watts Upper Critical : (0x72) +24.966 Upper Non-Critical : (0x61) +21.243
43	Board Reset	System Reset
44	EventRcv ComLost	Specify if the communication with the event receiver has been lost.
45	IPMI Watchdog	IPMI Watchdog As defined in the IPMI specification
46	IPMB0 Link State	IPMB-0 fault detection sensor As defined by PICMG 3.0 specification
47	FRU0 IPMBL State	IPMB-L fault detection sensor
48	FRU1 IPMBL State	IPMB-L fault detection sensor
49	FRU2 IPMBL State	IPMB-L fault detection sensor
50	FRU23IPMBL State	IPMB-L fault detection sensor
51	ACPI State	ACPI State
52	Health Error	General health status Aggregation of critical sensors This list is flexible and could be adjusted based on Customer requirements.
53	CPU 0 Status	CPU 0 Status Includes the following supported offset type: 00h - IERR 05h - Configuration Error 07h - Processor Presence Detected (no event)

IPMI sensor ID	Sensor Name	Description
54	CPU 0 ThermTrip	01h - Thermal Trip
55	CPU 1 Status	CPU 1 Status Includes the following supported offset type: 00h - IERR 05h - Configuration Error 07h - Processor Presence Detected (no event)
56	CPU 1 ThermTrip	01h - Thermal Trip
57	Memory	Memory Status Includes the following supported offset type: 00h - Correctable ECC 01h - Uncorrectable ECC 03h - Memory Scrub Failed (stuck bit) 04h - Memory Device Disabled 05h - Correctable ECC / Memory logging limit Reach
58	POST Value	Current POST Code Generates an event with current post CODE in data2/data3
59	POST Error	System Firmware Progress Includes the following supported offset type: 00h System Firmware Error (Post Error) Event Data 2: 00h - Unspecified (CMOS settings wrong, CMOS checksum bad, CMOS Date/Time Not set) 01h - No system memory is physically installed in the system 02h - No usable system memory 03h - Unrecoverable hard-disk/ATAPI/IDE device failure 04h - Unrecoverable system-board failure 0Dh - CPU speed matching failure
60	Critical Int	Critical Interrupt Includes the following supported offset type: 00h - Front Panel NMI 04h - PCI PERR 05h - PCI SERR
61	Boot Error	Boot Error Includes the following supported offset type: 00h - No bootable media
62	CmosMemorySize	POST Memory Resize Sensor Type: 0Eh Indicates if CMOS memory size is wrong
63	Preboot Password	Platform Security Violation Attempt Sensor Type: 06h Sensor Specific Offset: 01h - Pre-Boot Password Violation, User password (BIOS password check location is critical) 04h - Other Pre-Boot Password Violation (BIOS password check location is not critical)
64	FWH 0 Boot Error	Firmware Hub 0 Boot Error. Specifies if it was unable to boot from the BIOS on the Firmware Hub 0

IPMI sensor ID	Sensor Name	Description
65	FWH 1 Boot Error	Firmware Hub 1 Boot Error. Specifies if it was unable to boot from the BIOS on the Firmware Hub 1
66	FRU1 Mp Over Icc	FRU 1 Management Power Over Current
67	FRU1 Over Icc	FRU 1 Over Current
68	FRU1 Sensor Err	FRU 1 Error during Sensor discovery
69	FRU2 Mp Over Icc	FRU 2 Management Power Over Current
70	FRU2 Over Icc	FRU 2 Over Current
71	FRU2 Sensor Err	FRU 2 Error during Sensor discovery
72	FRU3 Mp Over Icc	FRU 3 Management Power Over Current
73	FRU3 Over Icc	FRU 3 Over Current
74	FRU3 Sensor Err	FRU 3 Error during Sensor discovery
75	FRU0 Pwr Denied	FRU 0 Power Denied
76	FRU1 Pwr Denied	FRU 1 Power Denied
77	FRU2 Pwr Denied	FRU 2 Power Denied
78	FRU3 Pwr Denied	FRU 3 Power Denied
79	FRU0 FRU Agent	Board FRU 0 Data agent that verifies FRU Data validity (checksum/E-key/etc)
80	FRU1 FRU Agent	Board FRU 0 Data agent that verifies FRU Data validity (checksum/E-key/etc)
81	FRU2 FRU Agent	Board FRU 0 Data agent that verifies FRU Data validity (checksum/E-key/etc)
82	FRU3 FRU Agent	Board FRU 0 Data agent that verifies FRU Data validity (checksum/E-key/etc)
83	IPMC Storage Err	Management sub-system health: non volatile memory error.
84	Firmware Upg Mng	Firmware Upgrade Manager Status
85	IpmC Reboot	IPMC reboot detection
86	Ver change	IPMC firmware upgrade detection
87	SEL State	SEL state Specifies if the SEL is full
88	IPMI Info-1	Internal IPMC firmware diagnostic
89	IPMI Info-2	Internal IPMC firmware diagnostic
91	DCM: Temp Board	
92	DCM:Temp LAN	
93	DCM:Vcc +1.1V	
94	DCM:Vcc +1.2V	
95	DCM:Vcc +1.8V	
96	DCM:Vcc +3.3V	
97	DCM:Vcc +3.3VSUS	
98	DCM:Vcc +12V	

## 2.15.4 Events supported

### 2.15.4.1 *IPMB Link Sensor*

The AT8020 provides two IPMB links to increase communication reliability to the shelf manager and other IPM devices on the IPMB bus. These IPMB links work together for increased throughput where both busses are actively used for communication at any point. A request might be received over IPMB Bus A, and the response is sent over IPMB Bus B. All requests that time out are retried on the redundant IPMB bus. In the events of any link state changes, the events are written to the AT8020 SEL. The IPMC monitors the bus for any link failure and isolates itself from the bus if it detects that it is causing errors on the bus. Events are sent to notify the failure of a bus or, conversely, the recovery of a bus.

### 2.15.4.2 *FRU Hot Swap*

The hot-swap event message conveys the previous and the current state of the FRU. Also, as the FRU state changes, the IPMC determines the cause and that info is added to the event. Refer to PICMG 3.0 specifications for further details about the hot-swap state.

## 2.15.4.3 OEM Sensor Types

### 2.15.4.3.1 Sensor Types

OEM Name	OEM Number	Descriptions (Including Associated Event/Reading type code)
OEM Firmware Info	C0h	<p>Sensor giving info about firmware state. According to the Event/Reading Type, the 2 first bits will have assertion mask set.</p> <p>Associated event/reading type code:            0x70-OEM Firmware Info 1            0x71-OEM Firmware Info 2            0x75-OEM Firmware Info 2</p>
IPMB-L Link State	C3h	<p>On an AMC carrier, the IPMB-L (for IPMB Local) is the link between the IPMC and the MMC. The IPMB-L doesn't require to support a failure detection sensor, as opposed to the IPMB-0, which is connected between the ShMC and the IPMC. However, since the AMC.0 specification contains several requirements about AMC IPMB-L fault detection and isolation, it was decided to include an IPMB-L failure detection sensor.</p> <p>This IPMB-L Link State sensor matches the PICMG 3.0 IPMB-0 Link State sensor (defined sensor type F1h). IPMB-0 sensor includes redundant channels IPMB-A and IPMB-B. See ATCA specification PICMG 3.0 R2.0 section 3.8.4 for all details related to this sensor.</p> <p>To define IPMB-L sensor, we had to take an OEM sensor type because the IPMB-0 type is reserved for Port Link A &amp; B.</p> <p>IPMB-L Sensor Port Link is placed at the same location as IPMB-A of IPMB-0 sensor. Compare to IPMB-0, all bytes related to IPMB-B are set to "enable-working" state. The sensor will only use the following bit offset.</p> <p>Sensor byte 4 bit offset:            [0] Reserved            [1] Reserved            [2] 1b = IPMB L disabled            [3] 1b = IPMB L enabled</p> <p>Associated event/reading type code:            This sensor match the ATCA defined type F1h.</p>
ATCA Reset Sensor	C4h	<p>Sensor giving information about board reset source. All defined bits will have assertion event mask set.</p> <p>Associated event/reading type code:            6Fh - IPMI Sensor Specific            (Formerly 76h OEM ATCA Reset Sensor)</p>
FIA Error Sensor	C5h	<p>Sensor indicating if there has been an error during the FRU Information Agent scan (used for E-Keying )</p> <p>Associated event/reading type code:            0Ah - DMI-Based Availability</p>
Post Value Sensor	C6h	<p>Sensor indicating the BIOS POST error code.</p> <p>Associated event/reading type code:            6Fh - IPMI Sensor Specific            (Formerly 78h OEM POST value Sensor)</p>
FWUM Status	C7h	<p>Sensor indicating the state of the Firmware Update Manager (for rollback and such )</p> <p>Associated event/reading type code:            6Fh - IPMI Sensor Specific            (Formerly 79h OEM FWUM Status)</p>

## 2.15.5 Field Replaceable Unit (FRU) Information

The FRU Information provides specific data about a board for servicing usage. Typical information, like the part number and board's version can be read via IPMI software tools. This information is retrieved by the shelf manager (ShMC), enabling reports of board-specific information through an out-of-band mechanism.

The following are definitions of multirecord implemented by the firmware as part of FRU data.

### 2.15.5.1 E-Keying

E-Keying has been defined in the PICMG 3.0 Specification to prevent board damage, prevent misoperation, and verify fabric compatibility. The FRU data contains the board point-to-point connectivity record as described in Section 3.7.2.3 of the PICMG 3.0 specification.

When the board enters M3 power state, the shelf manager reads in the board point-to-point connectivity record from FRU and determines whether the board can enable the Fibre Channel ports to the back plane. Set/Get Port State IPMI commands defined by the PICMG 3.0 specification are used for either granting or rejecting the E-keys.

Additional E-Keying is provided for connectivity between the AMC carrier and the AMC bays as described in the Section 3.9 and 3.7 of the AMC.0 RC.2.0 specification. The Set/Get AMC Port State IPMI commands defined by the AMC.0 specification are used for either granting or rejecting the E-keys.

### 2.15.5.2 FRU Multirecord

#### 2.15.5.2.1 Type 14 - Atca Board Point-To-Point Connectivity Record

Point-to-Point Connectivity Record	
Record Type ID	C0h
Record format version	02h
Manufacturer ID	00315Ah --> PICMG Record ID
PICMG Record ID	14h (ATCA Board Point-To-Point Connectivity Record)
Record Format Version	00h
OEM GUID Count	00h
Link Descriptor	00001101 h
Link Grouping ID (Bits 31-24)	0h --> Single Channel Link
Link Type Extension (Bits 23-20)	0h --> None
Link Type (Bits 19-12)	01h --> PICMG 3.0 Base Interface 10/100/1000 Base-T
Link Designator (Bits 11-0)	101h --> Base Interface, Channel 1, Port 0
Link Descriptor	00001102 h
Link Grouping ID (Bits 31-24)	0h --> Single Channel Link
Link Type Extension (Bits 23-20)	0h --> None
Link Type (Bits 19-12)	01h --> PICMG 3.0 Base Interface 10/100/1000 Base-T
Link Designator (Bits 11-0)	102h --> Base Interface, Channel 2, Port 0
Link Descriptor	00002341 h
Link Grouping ID (Bits 31-24)	0h --> Single Channel Link
Link Type Extension (Bits 23-20)	0h --> Fixed 1000 Base-BX

Point-to-Point Connectivity Record	
Link Type (Bits 19-12)	02h --> PICMG 3.1 Ethernet Fabric Interface
Link Designator (Bits 11-0)	341h --> Fabric Interface, Channel 1, Port 0 & 1
Link Descriptor	00002141 h
Link Grouping ID (Bits 31-24)	0h --> Single Channel Link
Link Type Extension (Bits 23-20)	0h --> Fixed 1000 Base-BX
Link Type (Bits 19-12)	02h --> PICMG 3.1 Ethernet Fabric Interface
Link Designator (Bits 11-0)	141h --> Fabric Interface, Channel 1, Port 0
Link Descriptor	00002441h
Link Grouping ID (Bits 31-24)	0h --> Single Channel Link
Link Type Extension (Bits 23-20)	0h --> Fixed 1000 Base-BX
Link Type (Bits 19-12)	02h --> PICMG 3.1 Ethernet Fabric Interface
Link Designator (Bits 11-0)	441h --> Fabric Interface, Channel 1, Port 2
Link Descriptor	00002342 h
Link Grouping ID (Bits 31-24)	0h --> Single Channel Link
Link Type Extension (Bits 23-20)	0h --> Fixed 1000 Base-BX
Link Type (Bits 19-12)	02h --> PICMG 3.1 Ethernet Fabric Interface
Link Designator (Bits 11-0)	342h --> Fabric Interface, Channel 2, Port 0 & 1
Link Descriptor	00002142 h
Link Grouping ID (Bits 31-24)	0h --> Single Channel Link
Link Type Extension (Bits 23-20)	0h --> Fixed 1000 Base-BX
Link Type (Bits 19-12)	02h --> PICMG 3.1 Ethernet Fabric interface
Link Designator (Bits 11-0)	141h --> Fabric Interface, Channel 2, Port 0
Link Descriptor	00002442 h
Link Grouping ID (Bits 31-24)	0h --> Single Channel Link
Link Type Extension (Bits 23-20)	0h --> Fixed 1000 Base-BX
Link Type (Bits 19-12)	02h --> PICMG 3.1 Ethernet Fabric interface
Link Designator (Bits 11-0)	442h --> Fabric Interface, Channel 2, Port 2

## 2.15.5.2.2 Type 17 - Carrier Activation And Current Management Record

Point-to-Point Connectivity Record	
Record Type ID	C0h
Record format version	02h
Manufacturer ID	00315Ah
PICMG Record ID	17h
Record Format Version	00h
Maximum Internal Current	1Eh (3.0 Amps at 12 V => 36 Watts)
Allowance for Module Activation Readiness	002h
Module Activation and Power Descriptor Count	03h
Carrier Activation and Power Descriptors.	7Ah, 19h, FFh
Local IPMB Address	7Ah
Maximum Module Current	19h (2.5 Amps at 12 V => 30 Watts)
Reserved	FFh
Carrier Activation and Power Descriptors.	7Ch, 19h, FFh
Local IPMB Address	7Ch
Maximum Module Current	19h (2.5 Amps at 12 V => 30 Watts)
Reserved	FFh
Carrier Activation and Power Descriptors.	90h, 15h, FFh
Local IPMB Address	90h
Maximum Module Current	15h (2.1 Amps at 12 V => 25.2 Watts)
Reserved	FFh

## 2.15.5.2.3 Type 18 - Carrier Point-To-Point Connectivity Record

Point-to-Point Connectivity Record	
Record Type ID	C0h
Record format version	02h
Record Length	N/A
Record Checksum	N/A
Header Checksum	N/A
Manufacturer ID	00315Ah (PICMG Record ID)
PICMG Record ID	18h (Carrier Point-To-Point Connectivity Record)
Record Format Version	00h
Point-to-Point AMC Resource Descriptor	
Resource ID	85h --> AMC Bay, Device 5 (AMC B1)
Point-to-Point Count	08h
Point-to-Point Resource Descriptor	000002h
Reserved (Bits 23-18)	0
Local Port (Bits 13-17)	0
Remote Port (Bit 12-8)	0
Remote Ressource ID (Bits 7-0)	02h --> Carrier, Device 2 (Xpoint GbE)
Point-to-Point Ressource Descriptor	002102h
Reserved (Bits 23-18)	0h
Local Port (Bits 13-17)	1
Remote Port (Bit 12-8)	1
Remote Ressource ID (Bits 7-0)	02h --> Carrier, Device 2 (Xpoint GbE)
Point-to-Point Resource Descriptor	004103h
Reserved (Bits 23-18)	0
Local Port (Bits 13-17)	2
Remote Port (Bit 12-8)	1
Remote Ressource ID (Bits 7-0)	03h --> Carrier, Device 3 (SAS Controller)
Point-to-Point Resource Descriptor	006004h
Reserved (Bits 23-18)	0
Local Port (Bits 13-17)	3
Remote Port (Bit 12-8)	0
Remote Ressource ID (Bits 7-0)	04h --> Carrier, Device 4 (Xpoint SAS)
Point-to-Point Resource Descriptor	008000h
Reserved (Bits 23-18)	0
Local Port (Bits 13-17)	4
Remote Port (Bit 12-8)	0
Remote Ressource ID (Bits 7-0)	00h --> Carrier, Device 0 (MCH PCI Express Port C)
Point-to-Point Resource Descriptor	00A100h
Reserved (Bits 23-18)	0
Local Port (Bits 13-17)	5
Remote Port (Bit 12-8)	1
Remote Ressource ID (Bits 7-0)	00h --> Carrier, Device 0 (MCH PCI Express Port C)

Point-to-Point Connectivity Record	
Point-to-Point Resource Descriptor	00C200h
Reserved (Bits 23-18)	0
Local Port (Bits 13-17)	6
Remote Port (Bit 12-8)	2
Remote Ressource ID (Bits 7-0)	00h --> Carrier, Device 0 (MCH PCI Express Port C)
Point-to-Point Resource Descriptor	00E300h
Reserved (Bits 23-18)	0
Local Port (Bits 13-17)	7
Remote Port (Bit 12-8)	3
Remote Ressource ID (Bits 7-0)	00h --> Carrier, Device 0 (MCH PCI Express Port C)
Point-to-Point AMC Resource Descriptor	
Resource ID	86h --> AMC Bay, Device 6 (AMC B2)
Point-to-Point Count	08
Point-to-Point Resource Descriptor	000202h
Reserved (Bits 23-18)	0
Local Port (Bits 13-17)	0
Remote Port (Bit 12-8)	2
Remote Ressource ID (Bits 7-0)	02h --> Carrier, Device 2 (Xpoint GbE)
Point-to-Point Resource Descriptor	002302h
Reserved (Bits 23-18)	0
Local Port (Bits 13-17)	1
Remote Port (Bit 12-8)	3
Remote Ressource ID (Bits 7-0)	02h --> Carrier, Device 2 (Xpoint GbE)
Point-to-Point Resource Descriptor	004003h
Reserved (Bits 23-18)	0
Local Port (Bits 13-17)	2
Remote Port (Bit 12-8)	0
Remote Ressource ID (Bits 7-0)	03h --> Carrier, Device 3 (SAS Controller)
Point-to-Point Resource Descriptor	006104h
Reserved (Bits 23-18)	0
Local Port (Bits 13-17)	3
Remote Port (Bit 12-8)	1
Remote Ressource ID (Bits 7-0)	04h --> Carrier, Device 4 (Xpoint SAS)
Point-to-Point Resource Descriptor	008001h
Reserved (Bits 23-18)	0
Local Port (Bits 13-17)	4
Remote Port (Bit 12-8)	0
Remote Ressource ID (Bits 7-0)	00h --> Carrier, Device 1 (MCH PCI Express Port B)
Point-to-Point Resource Descriptor	00A101h
Reserved (Bits 23-18)	0
Local Port (Bits 13-17)	5
Remote Port (Bit 12-8)	1

Point-to-Point Connectivity Record	
Remote Ressource ID (Bits 7-0)	00h --> Carrier, Device 1 (MCH PCI Express Port B)
Point-to-Point Resource Descriptor	00C201h
Reserved (Bits 23-18)	0
Local Port (Bits 13-17)	6
Remote Port (Bit 12-8)	2
Remote Ressource ID (Bits 7-0)	00h --> Carrier, Device 1 (MCH PCI Express Port B)

#### 2.15.5.2.4 Type 19h - AMC Point-To-Point Connectivity Record(1 of 4)(MCH PCI Express Port C)

Point-to-Point Connectivity Record	
Record Type ID	C0h
Record format version	02h
Record Length	N/A
Record Checksum	N/A
Header Checksum	N/A
Manufacturer ID	00315Ah --> PICMG Record ID
PICMG Record ID	19h --> AMC Point-To-Point Connectivity Record
Record Format Version	00h
Record Type/Connected-device ID	00h --> On-Carrier device, Device 0 (MCH PCI Express Port C)
AMC Channel Descriptor Count	01h
AMC Channel Descriptor	0F18820h
Reserved (Bits 23-20)	0Fh
Lane 3 Port Number (Bits 19-15)	03h
Lane 2 Port Number (Bits 14-10)	02h
Lane 1 Port Number (Bits 9-5)	01h
Lane 0 Port Number (Bits 4-0)	00h
AMC Link Descriptor	FE00102F00 h
Reserved (Bits 39-34)	03Fh
AMC Asymmetric Match (Bits 33-32)	10b --> This Carrier provides a Secondary PCI Express Port (Matches with '01b')
Link Grouping ID (Bits 31-24)	00h --> Single Channel Link
AMC Link Type Extension (Bits 23-20)	01h --> Carrier: Reference clock is spread spectrum
AMC Link Type (Bits 19-12)	002h --> AMC.1 PCI Express
AMC Link Designator (Bits 11-0)	0F00h --> AMC Channel 0, lane 0, 1, 2 and 3
AMC Link Descriptor	FE00002F00 h
Reserved (Bits 39-34)	03Fh
AMC Asymmetric Match (Bits 33-32)	10b --> This Carrier provides a Secondary PCI Express Port (Matches with '01b')
Link Grouping ID (Bits 31-24)	00h --> Single Channel Link
AMC Link Type Extension (Bits 23-20)	00h --> Carrier: Reference clock is not spread spectrum
AMC Link Type (Bits 19-12)	002h --> AMC.1 PCI Express
AMC Link Designator (Bits 11-0)	0F00h --> AMC Channel 0, lane 0, 1, 2 and 3

Point-to-Point Connectivity Record	
AMC Link Descriptor	FE00102100 h
Reserved (Bits 39-34)	03Fh
AMC Asymmetric Match (Bits 33-32)	10b --> This Carrier provides a Secondary PCI Express Port (Matches with '01b')
Link Grouping ID (Bits 31-24)	00h --> Single Channel Link
AMC Link Type Extension (Bits 23-20)	01h --> Carrier: Reference clock is spread spectrum
AMC Link Type (Bits 19-12)	002h --> AMC.1 PCI Express
AMC Link Designator (Bits 11-0)	0100h --> AMC Channel 0, lane 0
AMC Link Descriptor	FE00002100 h
Reserved (Bits 39-34)	03Fh
AMC Asymmetric Match (Bits 33-32)	10b --> This Carrier provides a Secondary PCI Express Port (Matches with '01b')
Link Grouping ID (Bits 31-24)	00h --> Single Channel Link
AMC Link Type Extension (Bits 23-20)	00h --> Carrier: Reference clock is not spread spectrum
AMC Link Type (Bits 19-12)	002h --> AMC.1 PCI Express
AMC Link Designator (Bits 11-0)	0100h --> AMC Channel 0, lane 0

## 2.15.5.2.5

## Type 19h - AMC Point-To-Point Connectivity Record (2 of 4) (MCH PCI Express Port B)

Point-to-Point Connectivity Record	
Record Type ID	C0h
Record format version	02h
Record Length	N/A
Record Checksum	N/A
Header Checksum	N/A
Manufacturer ID	00315Ah --> PICMG Record ID
PICMG Record ID	19h --> AMC Point-To-Point Connectivity Record
Record Format Version	00h
Record Type/Connected-device ID	01h --> On-Carrier device, Device 1 (MCH PCI Express Port B)
AMC Channel Descriptor Count	01h
AMC Channel Descriptor	0F18820h
Reserved (Bits 23-20)	0Fh
Lane 3 Port Number (Bits 19-15)	03h
Lane 2 Port Number (Bits 14-10)	02h
Lane 1 Port Number (Bits 9-5)	01h
Lane 0 Port Number (Bits 4-0)	00h
AMC Link Descriptor	FE00102F00 h
Reserved (Bits 39-34)	03Fh
AMC Asymmetric Match (Bits 33-32)	10b --> This Carrier provides a Secondary PCI Express Port (Matches with '01b')
Link Grouping ID (Bits 31-24)	00h --> Single Channel Link
AMC Link Type Extension (Bits 23-20)	01h --> Carrier: Reference clock is spread spectrum
AMC Link Type (Bits 19-12)	002h --> AMC.1 PCI Express
AMC Link Designator (Bits 11-0)	0F00h --> AMC Channel 0, lane 0, 1, 2 and 3
AMC Link Descriptor	FE00102100 h
Reserved (Bits 39-34)	03Fh
AMC Asymmetric Match (Bits 33-32)	10b --> This Carrier provides a Secondary PCI Express Port (Matches with '01b')
Link Grouping ID (Bits 31-24)	00h --> Single Channel Link
AMC Link Type Extension (Bits 23-20)	01h --> Carrier: Reference clock is spread spectrum
AMC Link Type (Bits 19-12)	002h --> AMC.1 PCI Express
AMC Link Designator (Bits 11-0)	0100h --> AMC Channel 0, lane 0
AMC Link Descriptor	FE00102F01 h
Reserved (Bits 39-34)	03Fh
AMC Asymmetric Match (Bits 33-32)	10b --> This Carrier provides a Secondary PCI Express Port (Matches with '01b')
Link Grouping ID (Bits 31-24)	00h --> Single Channel Link
AMC Link Type Extension (Bits 23-20)	01h --> Carrier: Reference clock is spread spectrum
AMC Link Type (Bits 19-12)	002h --> AMC.1 PCI Express
AMC Link Designator (Bits 11-0)	0F01h --> AMC Channel 1, lane 0, 1, 2 and 3
AMC Link Descriptor	FE00002F01 h

Point-to-Point Connectivity Record	
Reserved (Bits 39-34)	03Fh
AMC Asymmetric Match (Bits 33-32)	10b --> This Carrier provides a Secondary PCI Express Port (Matches with '01b')
Link Grouping ID (Bits 31-24)	00h --> Single Channel Link
AMC Link Type Extension (Bits 23-20)	00h --> Carrier: Reference clock is not spread spectrum
AMC Link Type (Bits 19-12)	002h --> AMC.1 PCI Express
AMC Link Designator (Bits 11-0)	0F01h --> AMC Channel 1, lane 0, 1, 2 and 3
AMC Link Descriptor	FE00102101 h
Reserved (Bits 39-34)	03Fh
AMC Asymmetric Match (Bits 33-32)	10b --> This Carrier provides a Secondary PCI Express Port (Matches with '01b')
Link Grouping ID (Bits 31-24)	00h --> Single Channel Link
AMC Link Type Extension (Bits 23-20)	01h --> Carrier: Reference clock is spread spectrum
AMC Link Type (Bits 19-12)	002h --> AMC.1 PCI Express
AMC Link Designator (Bits 11-0)	0101h --> AMC Channel 1, lane 0
AMC Link Descriptor	FE00002101 h
Reserved (Bits 39-34)	03Fh
AMC Asymmetric Match (Bits 33-32)	10b --> This Carrier provides a Secondary PCI Express Port (Matches with '01b')
Link Grouping ID (Bits 31-24)	00h --> Single Channel Link
AMC Link Type Extension (Bits 23-20)	00h --> Carrier: Reference clock is not spread spectrum
AMC Link Type (Bits 19-12)	002h --> AMC.1 PCI Express
AMC Link Designator (Bits 11-0)	0101h --> AMC Channel 1, lane 0

## 2.15.5.2.6 Type 19h - AMC Point-To-Point Connectivity Record (3 of 4) (Xpoint GbE)

Point-to-Point Connectivity Record	
Record Type ID	C0h
Record format version	02h
Record Length	N/A
Record Checksum	N/A
Header Checksum	N/A
Manufacturer ID	00315Ah --> PICMG Record ID
PICMG Record ID	19h --> AMC Point-To-Point Connectivity Record
Record Format Version	00h
Record Type/Connected-device ID	01h ' On-Carrier device, Device 2 (Xpoint GbE)
AMC Channel Descriptor Count	04h
AMC Channel Descriptor	0FFFFE0h
Reserved (Bits 23-20)	0Fh
Lane 3 Port Number (Bits 19-15)	1Fh
Lane 2 Port Number (Bits 14-10)	1Fh
Lane 1 Port Number (Bits 9-5)	1Fh
Lane 0 Port Number (Bits 4-0)	00h
AMC Channel Descriptor	0FFFFE1h
Reserved (Bits 23-20)	0Fh
Lane 3 Port Number (Bits 19-15)	1Fh
Lane 2 Port Number (Bits 14-10)	1Fh '
Lane 1 Port Number (Bits 9-5)	1Fh '
Lane 0 Port Number (Bits 4-0)	01h
AMC Channel Descriptor	0FFFFE2h
Reserved (Bits 23-20)	0Fh
Lane 3 Port Number (Bits 19-15)	1Fh
Lane 2 Port Number (Bits 14-10)	1Fh
Lane 1 Port Number (Bits 9-5)	1Fh
Lane 0 Port Number (Bits 4-0)	02h
AMC Channel Descriptor	0FFFFE3h
Reserved (Bits 23-20)	0Fh
Lane 3 Port Number (Bits 19-15)	1Fh
Lane 2 Port Number (Bits 14-10)	1Fh '
Lane 1 Port Number (Bits 9-5)	1Fh '
Lane 0 Port Number (Bits 4-0)	03h
AMC Link Descriptor	FC00005104h
Reserved (Bits 39-34)	03Fh
AMC Asymmetric Match (Bits 33-32)	00b --> Exact match
Link Grouping ID (Bits 31-24)	00h --> Single-Channel link
AMC Link Type Extension (Bits 23-20)	01h --> 1000 Base BX
AMC Link Type (Bits 19-12)	005h --> AMC.2 Ethernet
AMC Link Designator (Bits 11-0)	0104h --> AMC Channel 4, lane 0

Point-to-Point Connectivity Record	
AMC Link Descriptor	FC00005105h
Reserved (Bits 39-34)	03Fh
AMC Asymmetric Match (Bits 33-32)	00h --> Exact match
Link Grouping ID (Bits 31-24)	00h --> Single-Channel link
AMC Link Type Extension (Bits 23-20)	00h --> 1000 Base BX
AMC Link Type (Bits 19-12)	005h --> AMC.2 Ethernet
AMC Link Designator (Bits 11-0)	0105h --> AMC Channel 5, lane 0

### 2.15.5.2.7 Type 19h - AMC Point-To-Point Connectivity Record (4 of 4)

Point-to-Point Connectivity Record	
Record Type ID	C0h
Record format version	02h
Record Length	N/A
Record Checksum	N/A
Header Checksum	N/A
Manufacturer ID	00315Ah --> PICMG Record ID
PICMG Record ID	19h --> AMC Point-To-Point Connectivity Record
Record Format Version	00h
Record Type/Connected-device ID	03h --> On-Carrier device, Device 3 (SAS Controller)
AMC Channel Descriptor Count	02h
AMC Channel Descriptor	FFFFE0h
Reserved (Bits 23-20)	0Fh
Lane 3 Port Number (Bits 19-15)	1Fh
Lane 2 Port Number (Bits 14-10)	1Fh
Lane 1 Port Number (Bits 9-5)	1Fh
Lane 0 Port Number (Bits 4-0)	00h
AMC Channel Descriptor	FFFFE1h
Reserved (Bits 23-20)	0Fh
Lane 3 Port Number (Bits 19-15)	1Fh
Lane 2 Port Number (Bits 14-10)	1Fh
Lane 1 Port Number (Bits 9-5)	1Fh
Lane 0 Port Number (Bits 4-0)	01h
AMC Link Descriptor	FC00207106h
Reserved (Bits 39-34)	03Fh
AMC Asymmetric Match (Bits 33-32)	00b --> Exact match
Link Grouping ID (Bits 31-24)	00h --> Single-Channel link
AMC Link Type Extension (Bits 23-20)	02h --> Serially Attached SCSI/SATA
AMC Link Type (Bits 19-12)	007h --> AMC.3 Storage
AMC Link Designator (Bits 11-0)	0106h --> AMC Channel 6, lane 0
AMC Link Descriptor	FE00107106h

Point-to-Point Connectivity Record	
Reserved (Bits 39-34)	03Fh
AMC Asymmetric Match (Bits 33-32)	02h --> Implements SATA Client Interface
Link Grouping ID (Bits 31-24)	00h --> Single-Channel link
AMC Link Type Extension (Bits 23-20)	01h --> Serial ATA
AMC Link Type (Bits 19-12)	007h --> AMC.3 Storage
AMC Link Designator (Bits 11-0)	0106h --> AMC Channel 6, lane 0
AMC Link Descriptor	FC00207107h
Reserved (Bits 39-34)	03Fh
AMC Asymmetric Match (Bits 33-32)	020b --> Exact match
Link Grouping ID (Bits 31-24)	00h --> Single-Channel link
AMC Link Type Extension (Bits 23-20)	02h --> Serially Attached SCSI/SATA
AMC Link Type (Bits 19-12)	007h --> AMC.3 Storage
AMC Link Designator (Bits 11-0)	0107h --> AMC Channel 7, lane 0
AMC Link Descriptor	FE00107107h
Reserved (Bits 39-34)	03Fh
AMC Asymmetric Match (Bits 33-32)	02h --> Implements SATA Client Interface
Link Grouping ID (Bits 31-24)	00h --> Single-Channel link
AMC Link Type Extension (Bits 23-20)	01h --> Serial ATA
AMC Link Type (Bits 19-12)	007h --> AMC.3 Storage
AMC Link Designator (Bits 11-0)	0107h --> AMC Channel 7, lane 0

#### 2.15.5.2.8 Type 1Ah - Carrier Information Table

Point-to-Point Connectivity Record	
Record Type ID	C0h
Record format version	02h
Record Length	N/A
Record Checksum	N/A
Header Checksum	N/A
Manufacturer ID	00315Ah (PICMG Record ID)
PICMG Record ID	1Ah (Carrier Information Table)
Record Format Version	00h
AMC.0 Extension Version	01h (AMC.0 R2.0)
Carrier Site Number Count	02h
Carrier Site Number	05h
Carrier Site Number	06h

## 2.15.6 IPMI Over LAN (IOL) support

The AT8020 provides IPMI Over LAN support over the 2 Ethernet connections of the base interface. The 82571EB chip connected to the base interface is also connected to the IPMC. The IPMI Over LAN solution is

compatible with the IPMI 1.5 and IPMI 2.0 specification and support both RMCP and RMCP+ payload type. It is also supporting the SOL payload type as described in the section 2.16.7.

The 2 channels are referred as channel 1 and channel 2. They can be accessed through those numbers when you use the IPMI commands related to channels. Only one channel can be activated at a time.

The implementation supports up to 4 simultaneous sessions (only one can enable SOL payload).

If a session is inactive for 1 minute it will be closed automatically.

The BIOS provides some basic functionality to see and configure the IPMI Over LAN. Using the BIOS, the following parameters can be seen/setup: IP address, MAC address, Subnet Mask, Gateway address, Active LAN channel. Those settings are available in the BIOS section LAN configuration.

The recommended IPMI Over Lan / Serial Over LAN tools for Linux is IPMITool. This utility is available from the following web site: <http://ipmitool.sourceforge.net/index.html>.

### 2.15.6.1 Authentication, Integrity and Confidentiality

The AT8020 support 2 types of authentication for RMCP session connections: "None" and "Straight Password".

For RMCP+ session connections, the AT8020 support from Cipher ID 0 to Cipher Id 3. The following algorithms are supported:

- Authentication: RAKP-none, RAKP-HMAC-SHA1
- Integrity: None, HMAC-SHA1-96
- Confidentiality: None, AES-CBC-128

When RMCP authentication "NONE" or RMCP+ Cipher ID 0 is used, privilege level is limited to "User".

### 2.15.6.2 Users

5 users are available for IPMI Over LAN connections. The user 1 is defined by the IPMI specification and cannot be changed. The following tables show the pre-defined users. They can be changed using the proper IPMI commands (See supported IPMI commands set on AT8020 at section 2.16.12).

User ID	User Name	Password	Can be modified	Privileges
1	NULL	NULL	No	User
2	"admin"	"admin"	Yes	Administrator
3	Undefined	Undefined	Yes	Undefined
4	Undefined	Undefined	Undefined	Undefined
5	Undefined	Undefined	Undefined	Undefined

## 2.15.7 Serial Over LAN support (SOL)

Serial Over LAN (SOL) is the name for the redirection of baseboard serial controller traffic over an IPMI Session. The IPMC has connections to the primary serial port connected to the front panel and to the management port of the base interface Ethernet controller. The serial port is implemented in such way that if there is a cable connected to the RJ-45 connector, the traffic is directed to the cable and the IPMC only monitors traffic. If there is no cable connected, the traffic is directed to the IPMC. The AT8020 supports SOL payload within a RMCP+ connection as defined in the IPMI 2.0 specification.

To setup SOL, use the following procedure:

- Configure the IP address, Subnet Mask and Gateway address in the BIOS LAN configuration page.
- Set Active the LAN channel to use.
- In the BIOS menu Remote Access Configuration (See section 5.1), set the following parameters:
  - Remote Access to "enabled".
  - Primary Serial port number to COM1 or "both" for dual output (COM1 and COM2).
  - Serial Port Mode to the desire speed.
  - Flow control to "Software "or "hardware". (Flow control is required, do not use "None")
  - Terminal type to the desire value.

The recommended IPMI Over Lan / Serial Over LAN tools for Linux is IPMITool. This utility is available from the following web site: <http://ipmitool.sourceforge.net/index.html>.

## 2.15.8 IPMC Firmware Code

IPMC firmware code is organized into boot code and operational code, both of which are stored in a flash module. Upon an IPMC reset, the IPMC executes the boot code and performs the following:

- 1 Self test to verify the status of its hardware and memory.
- 2 Performs a checksum of the operational code.
- 3 Communicates with the Firmware Upgrade Manager (FWUM) in order to inform the IPMC watchdog that the actual IPMC firmware is suitable for execution.

Upon successful verification of the operational code checksum, the firmware will jump to the operational code.

## 2.15.9 IPMC Firmware Upgrade Procedure

It is important to use compatible BIOS, IPMC, FWUM and FPGA versions. Since all those software and hardware solutions are exchanging information, they must be in synch. Please always follow Kontron documentation for all your upgrade.

The recommended upgrade sequence must be : FPGA, FWUM, IPMC, BIOS.

It is possible to read the actual version of FPGA, FWUM and IPMC by using the tool IPMIFWU V3.98. The BIOS version is written at every boot during BIOS POST, you can also get it by entering BIOS Setup Menu. The BIOS Setup does also provide the IPMC firmware version, via the IPMI Menu.

IPMC Firmware upgrades can be done by using IPMITOOL. It has been designed to upgrade through any IPMI interface without payload impact

## 2.15.10 Updating AT8020 BIOS

The AMI Linux upgrade utility is used to upgrade the BIOS.

Please note that board needs to reboot in order to take advantage of the new BIOS.

It is important to use compatible BIOS, IPMC, FWUM and FPGA versions. Since all these software and hardware solution are exchanging information, they must be in synch. Please always follow Kontron documentation for all your upgrade.

The recommended upgrade sequence must be: FPGA, FWUM, IPMC, BIOS.

It is possible to read the actual version of FPGA, FWUM and IPMC by using the tool IPMIFWU V3.98. The BIOS version is written at every boot during BIOS POST, you can also get it by entering BIOS Setup Menu. The BIOS Setup does also provide the IPMC firmware version, via the IPMI Menu.

Type the following:

```
afulnx2 /i<BIOS_BIN_File_Name> /pbnc <enter>
```

(no space between /i and the filename)

/pbnc is for

b - Program Boot Block (Make sure JP1 11-12 is IN)

n - Program NVRAM

c - Destroy System CMOS

After the upgrade process is completed, reboot by typing

Ctrl-alt-del keys

During BIOS POST, enter BIOS Setup Menu by typing

Del key

In BIOS Setup Menu, make sure to select BIOS Optimal Default Settings by typing F9 key

## 2.15.11 IPMI commands set on AT8020

The next table presents the supported IPMI commands within the AT8020. All these commands are compatible to IPMI v1.5 and PICMG 3.0 specifications.

	IPMI Spec. section	NetFn	CMD	IPMI BMC requirement	Shelf Man. requirement	IPM Controller requirement	Kontron support on AT8020
IPM Device "Global" Commands				M	M	M	
Get Device ID	17.1	App	01h	M	M	M	Yes
Cold Reset	17.2	App	02h	0 <sup>3</sup>	0 <sup>3</sup>	0 <sup>3</sup>	Yes
Warm Reset	17.3	App	03h	0	0	0	No
Get Self Test Results	17.4	App	04h	M	M	M	Yes
Manufacturing Test On	17.5	App	05h	0	0	0	No
Set ACPI Power State	17.6	App	06h	0	0	0	Yes
Get ACPI Power State	17.7	App	07h	0 <sup>3</sup>	0 <sup>3</sup>	0 <sup>3</sup>	Yes
Get Device GUID	17.8	App	08h	0	0	0	No
Broadcast "Get Device ID" <sup>1</sup>	17.9	App	01h	0/M	M <sup>3,4</sup>	M <sup>3,4</sup>	Yes
BMC Watchdog Timer Commands				M	0/M <sup>18</sup>	0/M	Yes
Reset Watchdog Timer	21.5	App	22h	M	M	M	Yes
Set Watchdog Timer	21.6	App	24h	M	M	M	Yes
Get Watchdog Timer	21.7	App	25h	M	M	M	Yes
BMC Device and Messaging Commands <sup>5</sup>				M	M	0	
Set BMC Global Enables	18.1	App	2Eh	M	0/M <sup>5</sup>	0/M <sup>5</sup>	Yes
Get BMC Global Enables	18.2	App	2Fh	M	M <sup>5</sup>	0/M <sup>5</sup>	Yes
Clear Message Flags	18.3	App	30h	M	0/M <sup>5</sup>	0/M <sup>5</sup>	Yes
Get Message Flags	18.4	App	31h	M	0/M <sup>5</sup>	0/M <sup>5</sup>	Yes
Enable Message Channel Receive	18.5	App	32h	0	0	0	Yes
Get Message	18.6	App	33h	M	0/M <sup>5,9</sup>	0/M <sup>5,9</sup>	Yes
Send Message	18.7	App	34h	M	M	0/M <sup>5,9</sup>	Yes
Read Event Message Buffer	18.8	App	35h	0	0	0	Yes
Get BT Interface Capabilities	18.9	App	36h	M	0/M <sup>3,5</sup>	0/M <sup>3,5</sup>	Yes
Master Write-Read	18.10	App	52h	M	0/M <sup>3,5,17</sup>	0/M <sup>3,5,17</sup>	Yes
Get System GUID	18.13	App	37h	0	0 <sup>3</sup>	0 <sup>3</sup>	No
Get Channel Authentication Capabilities	18.12	App	38h	0	M <sup>3</sup>	0 <sup>3</sup>	Yes
Get Session Challenge	18.14	App	39h	0	M <sup>3</sup>	0 <sup>3</sup>	Yes
Activate Session	18.15	App	3Ah	0	M <sup>3</sup>	0 <sup>3</sup>	Yes
Set Session Privilege Level	18.16	App	3Bh	0	M <sup>3</sup>	0 <sup>3</sup>	Yes

	IPMI Spec. section	NetFn	CMD	IPMI BMC requirement	Shelf Man. requirement	IPM Controller requirement	Kontron support on AT8020
Close Session	18.17	App	3Ch	0	M <sup>3</sup>	O <sup>3</sup>	Yes
Get Session Info	18.18	App	3Dh	0	M <sup>3</sup>	O <sup>3</sup>	Yes
Get AuthCode	18.19	App	3Fh	0	M	0	Yes
Set Channel Access	18.20	App	40h	0	M <sup>3</sup>	O <sup>3</sup>	Yes
Get Channel Access	18.21	App	41h	0	M <sup>3</sup>	O <sup>3</sup>	Yes
Get Channel Info	18.22	App	42h	0	M <sup>3</sup>	O <sup>3</sup>	Yes
Set User Access	18.23	App	43h	0	M <sup>3</sup>	O <sup>3</sup>	Yes
Get User Access	18.24	App	44h	0	M <sup>3</sup>	O <sup>3</sup>	Yes
Set User Name	18.25	App	45h	0	M <sup>3</sup>	O <sup>3</sup>	Yes
Get User Name	18.26	App	46h	0	M <sup>3</sup>	O <sup>3</sup>	Yes
Set User Password	18.27	App	47h	0	M <sup>3</sup>	O <sup>3</sup>	Yes
Chassis Device Commands				0	0	0	
Get Chassis Capabilities	22.1	Chassis	00h	M	M <sup>6</sup>	0	Yes
Get Chassis Status	22.2	Chassis	01h	0/M <sup>3</sup>	M <sup>6</sup>	0	Yes
Chassis Control	22.3	Chassis	02h	0/M <sup>3</sup>	M <sup>6</sup>	0	Yes
Chassis Reset	22.4	Chassis	03h	0	0	0	No
Chassis Identify	22.5	Chassis	04h	0	0	0	No
Set Chassis Capabilities	22.6	Chassis	05h	0	0	0	No
Set Power Restore Policy	22.7	Chassis	06h	0	0	0	No
Get System Restart Cause	22.9	Chassis	07h	O <sup>3</sup>	O <sup>3</sup>	O <sup>3</sup>	No
Get System Restart Cause	22.10	Chassis	08h	O <sup>3</sup>	O <sup>3</sup>	O <sup>3</sup>	No
Get System Restart Cause	22.11	Chassis	09h	O <sup>3</sup>	O <sup>3</sup>	O <sup>3</sup>	No
Get System Restart Cause	22.12	Chassis	0Fh	O <sup>3</sup>	O <sup>3</sup>	O <sup>3</sup>	No
Event Commands				M	M	M	
Set Event Receiver	23.1	S/E	01h	M	M	M	Yes
Get Event Receiver	23.2	S/E	02h	M	M	M	Yes
Platform Event (a.k.a. "Event Message")	23.3	S/E	03h	M	M	M	Yes
PEF and Alerting Commands				0	0	0	
Get PEF Capabilities	24.1	S/E	10h	M <sup>3</sup>	M <sup>3</sup>	M <sup>3</sup>	No
Arm PEF Postpone Timer	24.2	S/E	11h	M <sup>3</sup>	M <sup>3</sup>	M <sup>3</sup>	No
Set PEF Configuration Parameters	24.3	S/E	12h	M <sup>3</sup>	M <sup>3</sup>	M <sup>3</sup>	No
Get PEF Configuration Parameters	24.4	S/E	13h	M <sup>3</sup>	M <sup>3</sup>	M <sup>3</sup>	No
Set Last Processed Event ID	24.5	S/E	14h	M <sup>3</sup>	M <sup>3</sup>	M <sup>3</sup>	No
Get Last Processed Event ID	24.6	S/E	15h	M <sup>3</sup>	M <sup>3</sup>	M <sup>3</sup>	No
Alert Immediate	24.7	S/E	16h	O <sup>3</sup>	O <sup>3</sup>	O <sup>3</sup>	No
PET Acknowledge	24.8	S/E	17h	O <sup>3</sup>	O <sup>3</sup>	O <sup>3</sup>	No
Sensor Device Commands				0	M	M	
Get Device SDR Info	29.2	S/E	20h	0	M	M	Yes

	IPMI Spec. section	NetFn	CMD	IPMI BMC requirement	Shelf Man. requirement	IPM Controller requirement	Kontron support on AT8020
Get Device SDR	29.3	S/E	21h	0 <sup>3</sup>	M <sup>3</sup>	M <sup>3</sup>	Yes
Reserve Device SDR Repository	29.4	S/E	22h	0 <sup>3</sup>	M <sup>3</sup>	M <sup>3</sup>	Yes
Get Sensor Reading Factors	29.5	S/E	23h	0 <sup>3</sup>	0 <sup>3</sup>	M <sup>3</sup>	No
Set Sensor Hysteresis	29.6	S/E	24h	0	0	0	Yes
Get Sensor Hysteresis	29.7	S/E	25h	0	0	0	Yes
Set Sensor Threshold	29.8	S/E	26h	0	0	0	Yes
Get Sensor Threshold	29.9	S/E	27h	0 <sup>3</sup>	0 <sup>3</sup>	0 <sup>3</sup>	Yes
Set Sensor Event Enable	29.10	S/E	28h	0	0	0	Yes
Get Sensor Event Enable	29.11	S/E	29h	0 <sup>3</sup>	0 <sup>3</sup>	0 <sup>3</sup>	Yes
Re-arm Sensor Events	29.12	S/E	2Ah	0 <sup>3</sup>	0 <sup>3</sup>	0 <sup>3</sup>	No
Get Sensor Event Status	29.13	S/E	2Bh	0	0	0	No
Get Sensor Reading	29.14	S/E	2Dh	M	M	M	Yes
Set Sensor Type	29.15	S/E	2Eh	0	0	0	No
Get Sensor Type	29.16	S/E	2Fh	0 <sup>3</sup>	0 <sup>3</sup>	0 <sup>3</sup>	No
FRU Device Commands				M	M	M	
Get FRU Inventory Area Info	28.1	Storage	10h	M	M	M	Yes
Read FRU Data	28.2	Storage	11h	M	M	M	Yes
Write FRU Data	28.3	Storage	12h	M	M	M	Yes
SDR Device Commands				M	M <sup>7</sup>	0 <sup>7</sup>	
Get SDR Repository Info	27.9	Storage	20h	M	M	M	No
Get SDR Repository Allocation Info	27.10	Storage	21h	0	0	0	No
Reserve SDR Repository	27.11	Storage	22h	M	M	M	No
Get SDR	27.12	Storage	23h	M <sup>3</sup>	M <sup>3</sup>	M <sup>3</sup>	No
Add SDR	27.13	Storage	24h	M <sup>3</sup>	M <sup>3,16</sup>	0/M <sup>3,5</sup>	No
Partial Add SDR	27.14	Storage	25h	M <sup>3</sup>	M <sup>3,16</sup>	0/M <sup>3,5</sup>	No
Delete SDR	27.15	Storage	26h	0 <sup>3</sup>	0 <sup>3</sup>	0 <sup>3</sup>	No
Clear SDR Repository	27.16	Storage	27h	M <sup>3</sup>	M <sup>3,16</sup>	0/M <sup>3,5</sup>	No
Get SDR Repository Time	27.17	Storage	28h	0/M <sup>3</sup>	0/M <sup>3</sup>	0/M <sup>3</sup>	No
Set SDR Repository Time	27.18	Storage	29h	0/M <sup>3</sup>	0/M <sup>3</sup>	0/M <sup>3</sup>	No
Enter SDR Repository Update Mode	27.19	Storage	2Ah	0 <sup>3</sup>	0 <sup>3</sup>	0 <sup>3</sup>	No
Exit SDR Repository Update Mode	27.20	Storage	2Bh	M <sup>3</sup>	M <sup>3</sup>	M <sup>3</sup>	No
Run Initialization Agent	27.21	Storage	2Ch	0 <sup>3</sup>	0 <sup>3</sup>	0 <sup>3</sup>	No
SEL Device Commands				M	M	0 <sup>8</sup>	
Get SEL Info	25.2	Storage	40h	M	M	M	Yes
Get SEL Allocation Info	25.3	Storage	41h	0	0	0	No
Reserve SEL	25.4	Storage	42h	0 <sup>3</sup>	0 <sup>3</sup>	0 <sup>3</sup>	No
Get SEL Entry	25.5	Storage	43h	M	M	M	Yes

	IPMI Spec. section	NetFn	CMD	IPMI BMC requirement	Shelf Man. requirement	IPM Controller requirement	Kontron support on AT8020
Add SEL Entry	25.6	Storage	44h	M <sup>3</sup>	M <sup>3</sup>	M <sup>3</sup>	Yes
Partial Add SEL Entry	25.7	Storage	45h	M <sup>3</sup>	M <sup>3</sup>	M <sup>3</sup>	Yes
Delete SEL Entry	25.8	Storage	46h	0	0	0	No
Clear SEL	25.9	Storage	47h	M	M	M	Yes
Get SEL Time	25.10	Storage	48h	M	M	M	Yes
Set SEL Time	25.11	Storage	49h	M	M	M	Yes
Get Auxiliary Log Status	25.12	Storage	5Ah	0	0	0	No
Set Auxiliary Log Status	25.13	Storage	5Bh	0 <sup>3</sup>	0 <sup>3</sup>	0 <sup>3</sup>	No
LAN Device Commands				0	M	0	
Set LAN Configuration Parameters	19.1	Transport	01h	0/M <sup>3</sup>	M <sup>3</sup>	0/M <sup>3</sup>	Yes
Get LAN Configuration Parameters	19.2	Transport	02h	0/M <sup>3</sup>	M <sup>3</sup>	0/M <sup>3</sup>	Yes
Suspend BMC ARPs	19.3	Transport	03h	0/M <sup>3</sup>	0/M <sup>3</sup>	0/M <sup>3</sup>	Yes
Get IP/UDP/RMCP Statistics	19.4	Transport	04h	0	0	0	No
Serial/Modem Device Commands				0	0	0	
Set Serial/Modem Configuration	20.1	Transport	10h	0/M <sup>3</sup>	0/M <sup>3</sup>	0/M <sup>3</sup>	No
Get Serial/Modem Configuration	20.2	Transport	11h	0/M <sup>3</sup>	0/M <sup>3</sup>	0/M <sup>3</sup>	No
Set Serial/Modem Mux	20.3	Transport	12h	0 <sup>3</sup>	0 <sup>3</sup>	0 <sup>3</sup>	No
Get TAP Response Codes	20.4	Transport	13h	0 <sup>3</sup>	0 <sup>3</sup>	0 <sup>3</sup>	No
Set PPP UDP Proxy Transmit Data	20.5	Transport	14h	0 <sup>3</sup>	0 <sup>3</sup>	0 <sup>3</sup>	No
Get PPP UDP Proxy Transmit Data	20.6	Transport	15h	0 <sup>3</sup>	0 <sup>3</sup>	0 <sup>3</sup>	No
Send PPP UDP Proxy Packet	20.7	Transport	16h	0 <sup>3</sup>	0 <sup>3</sup>	0 <sup>3</sup>	No
Get PPP UDP Proxy Receive Data	20.8	Transport	17h	0 <sup>3</sup>	0 <sup>3</sup>	0 <sup>3</sup>	No
Serial/Modem Connection Active	20.9	Transport	18h	0/M <sup>3</sup>	0/M <sup>3</sup>	0/M <sup>3</sup>	No
Callback	20.10	Transport	19h	0	0	0	No
Set User Callback Options	20.11	Transport	1Ah	0 <sup>3</sup>	0 <sup>3</sup>	0 <sup>3</sup>	No
Get User Callback Options	20.12	Transport	1Bh	0 <sup>3</sup>	0 <sup>3</sup>	0 <sup>3</sup>	No
Bridge Management Commands (ICMB) <sup>2</sup>				0	0	0	
Get Bridge State	ICMB	Bridge	00h	0/M <sup>2</sup>	0/M <sup>2</sup>	0	No
Set Bridge State	ICMB	Bridge	01h	0/M <sup>2</sup>	0/M <sup>2</sup>	0	No
Get ICMB Address	ICMB	Bridge	02h	0/M <sup>2</sup>	0/M <sup>2</sup>	0	No
Set ICMB Address	ICMB	Bridge	03h	0/M <sup>2</sup>	0/M <sup>2</sup>	0	No
Set Bridge Proxy Address	ICMB	Bridge	04h	0/M <sup>2</sup>	0/M <sup>2</sup>	0	No
Get Bridge Statistics	ICMB	Bridge	05h	0/M <sup>2</sup>	0/M <sup>2</sup>	0	No

	IPMI Spec. section	NetFn	CMD	IPMI BMC requirement	Shelf Man. requirement	IPM Controller requirement	Kontron support on AT8020
Get ICMB Capabilities	ICMB	Bridge	06h	0/M <sup>2</sup>	0/M <sup>2</sup>	0	No
Clear Bridge Statistics	ICMB	Bridge	08h	0/M <sup>2</sup>	0/M <sup>2</sup>	0	No
Get Bridge Proxy Address	ICMB	Bridge	09h	0/M <sup>2</sup>	0/M <sup>2</sup>	0	No
Get ICMB Connector Info	ICMB	Bridge	0Ah	0/M <sup>2</sup>	0/M <sup>2</sup>	0	No
Get ICMB Connection ID	ICMB	Bridge	0Bh	0/M <sup>2</sup>	0/M <sup>2</sup>	0	No
Send ICMB Connection ID	ICMB	Bridge	0Ch	0/M <sup>2</sup>	0/M <sup>2</sup>	0	No
Discovery Commands (ICMB) <sup>2</sup>				0	0	0	
Prepare For Discovery	ICMB	Bridge	10h	0/M <sup>2</sup>	0/M <sup>2</sup>	0	No
Get Addresses	ICMB	Bridge	11h	0/M <sup>2</sup>	0/M <sup>2</sup>	0	No
Set Discovered	ICMB	Bridge	12h	0/M <sup>2</sup>	0/M <sup>2</sup>	0	No
Get Chassis Device ID	ICMB	Bridge	13h	0/M <sup>2</sup>	0/M <sup>2</sup>	0	No
Set Chassis Device ID	ICMB	Bridge	14h	0/M <sup>2</sup>	0/M <sup>2</sup>	0	No
Bridging Commands (ICMB) <sup>2</sup>				0	0	0	
Bridge Request	ICMB	Bridge	20h	0/M <sup>2</sup>	0/M <sup>2</sup>	0	No
Bridge Message	ICMB	Bridge	21h	0/M <sup>2</sup>	0/M <sup>2</sup>	0	No
Event Commands (ICMB) <sup>2</sup>				0	0	0	
Get Event Count	ICMB	Bridge	30h	0/M <sup>2</sup>	0/M <sup>2</sup>	0	No
Set Event Destination	ICMB	Bridge	31h	0/M <sup>2</sup>	0/M <sup>2</sup>	0	No
Set Event Reception State	ICMB	Bridge	32h	0/M <sup>2</sup>	0/M <sup>2</sup>	0	No
Send ICMB Event Message	ICMB	Bridge	33h	0/M <sup>2</sup>	0/M <sup>2</sup>	0	No
Get Event Destination	ICMB	Bridge	34h	0/M <sup>2</sup>	0/M <sup>2</sup>	0	No
Get Event Reception State	ICMB	Bridge	35h	0/M <sup>2</sup>	0/M <sup>2</sup>	0	No
OEM Commands for Bridge NetFn				0	0	0	
OEM Commands	ICMB	Bridge	C0h-FEh	0/M <sup>2</sup>	0/M <sup>2</sup>	0	No
Other Bridge Commands				0	0	0	
Error Report	ICMB	Bridge	FFh	0/M <sup>2</sup>	0/M <sup>2</sup>	0	No
AdvancedTCA <sup>10</sup>	PICMG 3.0 Table				M	M	
Get PICMG Properties	3-9	PICMG	00h		M	M	Yes
Get Address Info	3-8	PICMG	01h		M	M <sup>12</sup>	Yes
Get Shelf Address Info	3-13	PICMG	02h		M	0	No
Set Shelf Address Info	3-14	PICMG	03h		M	0	No
FRU Control	3-22	PICMG	04h		M	M	Yes
Get FRU LED Properties	3-24	PICMG	05h		M	M	Yes
Get LED Color Capabilities	3-25	PICMG	06h		M	M	Yes
Set FRU LED State	3-26	PICMG	07h		M	M	Yes
Get FRU LED State	3-27	PICMG	08h		M	M	Yes
Set IPMB State	3-51	PICMG	09h		M	M	Yes
Set FRU Activation Policy	3-17	PICMG	0Ah		M	M	Yes
Get FRU Activation Policy	3-18	PICMG	0Bh		M	M	Yes

	IPMI Spec. section	NetFn	CMD	IPMI BMC requirement	Shelf Man. requirement	IPM Controller requirement	Kontron support on AT8020
Set FRU Activation	3-16	PICMG	0Ch		M	M	Yes
Get Device Locator Record ID	3-29	PICMG	0Dh		O/M <sup>15</sup>	M	Yes
Set Port State	3-41	PICMG	0Eh		O/M <sup>13</sup>	O/M <sup>13</sup>	Yes
Get Port State	3-42	PICMG	0Fh		O/M <sup>13</sup>	O/M <sup>13</sup>	Yes
Compute Power Properties	3-60	PICMG	10h		M <sup>15</sup>	M	Yes
Set Power Level	3-62	PICMG	11h		M <sup>15</sup>	M	Yes
Get Power Level	3-61	PICMG	12h		M <sup>15</sup>	M	Yes
Renegotiate Power	3-66	PICMG	13h		M	O	No
Get Fan Speed Properties	3-63	PICMG	14h		M <sup>11</sup>	M <sup>11</sup>	No
Set Fan Level	3-65	PICMG	15h		O/M <sup>11</sup>	O/M <sup>11</sup>	No
Get Fan Level	3-64	PICMG	16h		O/M <sup>11</sup>	O/M <sup>11</sup>	No
Bused Resource	3-44	PICMG	17h		O/M	O/M <sup>14</sup>	No
Get IPMB Link Info	3-49	PICMG	18h		O/M <sup>19</sup>	O/M <sup>19</sup>	No

- 1 This command is sent using the Broadcast format on IPMB. See command description for details.
- 2 See ICMB specification for details. If an ICMB is implemented, then these commands are mandatory. However, methods to implement dual Shelf Managers with ICMB interfaces are not defined by either PICMG 3.0 or the ICMB specification.
- 3 Additional constraints apply, see appropriate IPMI v1.5 section for details.
- 4 PICMG 3.0 requires IPMB-0 (Channel 0) for ShMC to IPM Controller communication.
- 5 PICMG 3.0 doesn't require the implementation of KCS, SMIC or BT system interfaces on any IPM controller, including a ShMC. PICMG 3.0 designates a Payload Interface between an IPM Controller and its Payload, but does not constrain the implementation of that interface. However, if any IPMI-defined system interface is to be implemented, these commands are mandatory.
- 6 The Shelf Manager shall apply this command to an entire Shelf.
- 7 PICMG 3.0 does not require a centralized SDR Repository in the Shelf Manager, though a partial SDR repository is necessary on the Shelf Manager.
- 8 IPMI does not allow for multiple SELs. However, PICMG 3.0 does allow for optional SELs on the IPM Controllers since it may be appropriate for some architectures.
- 9 These commands are required if a System Manager Interface or other Channels are supported.
- 10 All AdvancedTCA and PICMG specific request commands use the NetFN 2Ch with the PICMG identifier 00h. The response uses NetFN 2Dh with the PICMG identifier 00h.
- 11 These commands are required by the IPM Controllers that control Shelf fans.
- 12 IPM Controllers are only required to support a subset of this command, see Section 3.2.3, "Addressing," for details.
- 13 These commands are only mandatory for Boards that implement E-Keying-governed interfaces.
- 14 These commands are only mandatory for Boards that implement E-Keying-governed shared bus interfaces, namely the Synchronization Clocks and Metallic Test Bus.
- 15 Mandatory group for Shelf Managers that act as either an active or backup Shelf Manager.
- 16 Mandatory for at least the System Manager Interface on the Shelf Manager.
- 17 Since non-intelligent devices are not allowed to attach to either IPMB-A or IPMB-B, this command is optional for those two buses.
- 18 For the Shelf Manager, these WDT commands are mandatory only if there is a Payload function associated with the ShMC.
- 19 Mandatory for IPM Controllers that incorporate an IPMB-0 Hub

## 2.15.12 OEM IPMI Commands

This section documents the OEM style IPMI commands implemented and supported on the AT8020.

Command Name	NetFunction	Command
Reset BIOS Flash Type	3Ah	01h
SetBoardDeviceChannelPortSelection	3Ah	10h
GetBoardDeviceChannelPortSelection	3Ah	11h
GetBoardDevicePossibleSelection	3Ah	13h
Set Control State	3Eh	20h
Get Control State	3Eh	21h

### 2.15.12.1 *Reset BIOS Flash Type*

This command resets the processor and changes the BIOS bank select signal so that CPU boots off redundant BIOS bank.

	7	6	5	4	3	2	1	0
NetFn/LUN	NetFn = 3Ah (OEM Request)						RsLUN	
Command	Cmd = 01h							
Byte 1	BIOS checksum success/failure indication 00h Checksum success 01h Checksum failure							
Byte 1	Completion code							

### 2.15.12.2 *Set Control State*

This command sets the state of a control pin and overrides the control pin's auto state

	7	6	5	4	3	2	1	0
NetFn/LUN	NetFn = 3Eh (OEM Request)						RsLUN	
Command	Cmd = 20h							
Byte 1	Control number							
Byte 2	Control state, 0 = Deassert, 1 = Assert, 3 = Reserved, FF = Don't change settings							
Byte 1	Completion code							

### 2.15.12.3 *Get Control State*

This command sets the state of a control pin. This command overrides the AUTO-state of the control pin.

	7	6	5	4	3	2	1	0
NetFn/LUN	NetFn = 3Eh (OEM Request)						RsLUN	

	7	6	5	4	3	2	1	0
Command	Cmd = 21h							
Byte 1	Control number							
Byte 1	Completion code							
Byte 2	Control state, 0 = Deassert, 1 = Assert, 3 = Reserved, FF = Don't change settings							

#### 2.15.12.4 *GetBoardDeviceChannelPortSelection*

This command returns the current device 'routing' selection. The command is available over any working interface.

Request Data	1 - 3	Kontron IANA number (003A98h) LSB first, MSB last
	4	Device to select port. (see below)
Response Data	1	Completion Code
	2-4	Kontron IANA number (003A98h) LSB first, MSB last
	5	Device channel/port selection (see below)
	6	Device channel/port HW setting (see below)

Device list:

19h: PCIe Clock

Channel / port list:

19h: PCIe Clock SSC Mode

1Ah: PCIe Clock Non-SSC Mode

#### 2.15.12.5 *SetBoardDeviceChannelPortSelection*

This command selects the onboard device port 'routing' as specified in the request data bytes. The command is available on any working interface.

Request Data	1 - 3	Kontron IANA number (003A98h) LSB first, MSB last
	4	Device to select port. (see below)
	5	Device channel/port selection (see below)
Response Data	1	Completion Code
	2 - 4	Kontron IANA number (003A98h) LSB first, MSB last

Device list:

19h: PCIe Clock

Channel / port list:

19h: PCIe Clock SSC Mode

1Ah: PCIe Clock Non-SSC Mode

### 2.15.12.6 Controls Identifier Table

This table lists the control identifiers that can be used with Set/Get Control State IPMI commands to query or set information on certain controls in the firmware.

Control Description	Control Number
FWH Hub (for BIOS bank information)0	0

## 2.15.13 Hot-Swap Process

The AT8020 SBC has the ability to be hot-swapped in and out of a chassis. The onboard IPMC manages the SBC's power-up and power-down transitions. The list below illustrates this process for power down request.

- 1 Ejector latch is opened. HOT\_SWAP\_PB# assertion. IPMC firmware detects the assertion of this signal.
- 2 IPMC sends "Deactivation Request" message to SHMC. M state moves from M4-> M5.
- 3 Board moves from M5 -> M6 if the SHMC grants the request.
- 4 The IPMC's ACPI timer (3 minutes) starts if an ACPI-enable OS is loaded. Otherwise, it goes to Step 7 below. The IPMC asserts 20 ms pulse on SMC\_PWRBTN#.
- 5 The Power Button Status register is set. It then asserts SCI# to the OS. If ACPI OS is enabled, SCI interrupt handler on the OS is called. Interrupt handler clears PWRBTN\_STS bit. OS starts to perform a graceful shutdown.
- 6 The firmware deasserts payload power and sets the IPMI locked bit before it transitions from M6 to M1 state.



#### Note:

If the upper-level software moves the IPMC to M6, the same procedure is followed, starting with Step 4.

### 2.15.13.1 Hot-Swap LED

The AT8020 SBC supports a blue Hot Swap LED mounted on the front panel. The position of this LED is near the bottom handle. This LED indicates when it is safe to remove the SBC from the chassis. The on-board IPMC drives this LED to indicate the hot-swap state. The following states are possible:

LED state	Description
OFF	Board is in M4 state, normal state when board is in operation.
ON	Ready for hot swap.
Short blink	M5 state deactivation request
Long blink	M2 state Activation Request.

When the lower ejector handle is disengaged from the faceplate, the hot swap switch embedded in the PCB will assert a signal to the IPMC, and the IPMC will move from the M4 state to the M5 state. At the M5 state, the IPMC will ask the SHMC (or Shelf Manager) for permission to move to the M6 state. The Hot Swap LED will indicate this state with a short blink. Once permission is received from the SHMC or higher-level software, the SBC will move to the M6 state.

The SHMC or higher level software can reject the request to move to the M6 state. If this occurs, the Hot Swap LED returns to a solid off condition, indicating that the SBC has returned to M4 state.

If the SBC reaches the M6 state, either through an extraction request through the lower ejector handle or a direct command from higher-level software and an ACPI-enabled OS is loaded on the SBC, the IPMC communicates to the OS that the module must discontinue operation in preparation for removal. The Hot Swap LED continues to flash during this preparation time, just like it does at the M5 state. When main board power is successfully removed from the SBC, the Hot Swap LED remains lit, indicating it is safe to remove the SBC from the chassis.

LED Status	Meaning
Off	Normal status
Blinking Blue	Preparing for removal/insertion: Long blink indicates activation is in progress, short blink when deactivation is in progress.
Solid Blue	Ready for hot swap

### 2.15.13.2 Ejector Mechanism

In addition to captive retaining screws, the AT8020 SBC has two ejector mechanisms to provide a positive cam action; this ensures the blade is properly seated. The bottom ejector handle also has a switch that is connected to the IPMC.

### 2.15.13.3 OOS Led (ATCA Led 1)

The AT8020 SBC supports a red Out Of Service LED mounted on the front panel. The LED is near the Lan A connector. The on-board FWUM or the IPMC can drive this LED to indicate the service state of the IPMC. The OEM application can also drive this LED using the PICMG LED control APIs. The following states are possible:

LED state	Description
OFF	Normal/Idle board is in service, unless blue led is on
ON	Out of service condition, IPMC is hold in reset
Short blink	Power denied condition detected: Payload has been left in M3 for more than 30secs or SetPowerLevel '0' has been received while in M2 or M3
Blink (50/50)	The FWUM is currently programming the IPMC

Other, application defined LED usage may be implemented.

The AT8020 AMC.0 carrier board also implements the OOS LED "Short blink" mode for its AdvancedMC mates on detection of "power denied" conditions.

LED state	Description
Short blink	Power denied condition detected: AMC current draw requirements exceed carrier power budget or SetPowerLevel '0' has been received while in M2 or M3

As per AMC.0, if the AMC current draw requirements exceed AMC.0 carrier power budget, the AT8020 will keep the AMC in M1 state with the blue HotSwap LED in the ON state.

## 2.16 Debugging Features

### 2.16.1 Lamp Test

The lamp test does the sequence shown below in the order 1-2-3-4-1-2-3- etc. Step 4 is not displayed when the regional bit is set for Europe (no red allowed). The lamp test can be initiated by keeping the reset pushbutton pressed.

LED arrangement and face plate finish may vary depending on board configuration.

No LEDs	#1
All green & blue LEDs	#2
All amber LEDs	#3
All red LEDs	#4

# 3. Installing the Board

## 3.1 Setting Jumpers

### 3.1.1 Jumper Description

Name	Description	Jumper
Watchdog	When the jumper is ON, it disables the watchdog.	JP1 (1-2)
Shelf Manager Activation	When the jumper is ON, it overrides the shelf manager activation.	JP1 (3-4)
IPMI	When the jumper is ON, the board is always on; it overrides the IPMI.	JP1 (5-6)
AMC Activation	When the jumper is ON, it overrides the AMC activation.	JP1 (7-8)
Reserved	Leave the jumper OUT.	JP1 (9-10)
FWH Top-block Protect	When the jumper is ON, write protect is disabled	JP1 (11-12)
FPGA PROM Selection	When the jumper is ON, it's the factory PROM; when it's OUT, it's the user PROM.	JP1 (13-14)
Reserved	Leave the jumper OUT.	JP2 (1-2)
Postcodes Display	When the jumper is ON, it display the postcodes.	JP2 (3-4)
BIOS Serial Recovery	When the jumper is ON, it does a BIOS serial recovery.	JP2 (5-6)
Reserved	Leave the jumper OUT.	JP2 (7-8)
Reserved	Leave the jumper OUT.	JP2 (9-10)
Clear CMOS Setup in Flash	When the jumper is ON, it restores on boot the CMOS's setup in flash.	JP2 (11-12)
Flash drive write protect	When the jumper is ON, it disables the possibility to write on the onboard flash drive.	JP2 (13-14)

### 3.1.2 Setting Jumper & Locations

**JUMPER SETTINGS** (● Default Setting)

<b>JP1 (1-2) Watchdog</b>		<b>JP2 (1-2) Reserved</b>	
Disabled	in	Reserved	in
Enabled	out	Reserved	out
<b>JP1 (3-4) Shelf Manager Activation</b>		<b>JP2 (3-4) Postcodes Display</b>	
Override	in	Reserved	in
Normal Operation	out	Normal BIOS postcodes	out
<b>JP1 (5-6) IPMI</b>		<b>JP2 (5-6) BIOS Recovery</b>	
Override (Board always ON)	in	Recovery Mode	in
Normal Operation	out	Normal Operation	out
<b>JP1 (7-8) AMC Activation</b>		<b>JP2 (7-8) Reserved</b>	
Override	in	Reserved	in
Normal Operation	out	Reserved	out
<b>JP1 (9-10) Reserved</b>		<b>JP2 (9-10) Reserved</b>	
Reserved	in	Reserved	in
Reserved	out	Reserved	out
<b>JP1 (11-12) FWH Top-block Protect</b>		<b>JP2 (11-12) Clear CMOS Setup</b>	
Unprotect	in	Restore on Boot	in
Normal	out	Normal Operation	out
<b>JP1 (13-14) FPGA PROM Selection</b>		<b>JP2 (13-14) Flash drive write protect</b>	
Factory Default	in	Protection controlled by BIOS	in
Normal Operation	out	Write Enabled	out

The diagram illustrates the physical locations of the jumpers on the board. JP1 jumpers are arranged in two columns on the left side, with labels for Channel B, Channel A, Channel A, and Channel B. JP2 jumpers are arranged in two columns on the right side. Other components labeled include J5, J6, J13, J14, and an Intel MCH 7520 chip.

## 3.2 Processor

This product ships with the CPU installed and a thermal solution installed. Because the thermal solution is custom and the thermal interface is critical for passive cooling, Kontron does not guarantee thermal performance if the heatsink is removed and then reinstalled by the end user.

## 3.3 Memory

The unit supports four 240 pin, 22.5 degree DIMM sockets. There are two parallel memory channels operating as a logical one, wide memory channel. The unit can also be operated with a single memory channel only (the chipset also enables these memory channels to operate in mirrored mode or to use spare DIMMs). When both memory channels are used there must be at least two DIMMs equipped. These DIMMs in parallel must be identical (identical size, speed and organization).

The memory bus operates at 200MHz clock speed with dual data rate (data is transferred at 400MHz). DDR2-400, 1.8V, max 1.2 inches high registered DIMMs must be used. The maximum DDR2 SDRAM size is 16GB. This maximum will depend on the board configuration. The minimum size of DDR2 SDRAM is 256MB, if only a single 256MB DIMM is used in single channel mode. For dual channel mode the minimum size is 512MB with two DIMMs.

The unit does support "single sided" and "dual sided" memory modules. All DIMM types supported by the MCH are supported by the AT8020. Also, both one row and two row DIMMs are supported.

Only use validated memory with this product. Thermal issues or other problems may arise if you don't use recommended modules. At the time of publication of this user guide, the following memory were confirmed functional with the product. As the memory market is volatile, this list is subject to change, please consult your local technical support for an up to date list.

Manufacturer Part Number	Description	Company
MT18HTF12872Y-40EA2	DIMM DDR2-400 1GB 128M*72 REG ECC 1.2"	Micron Technology, Inc.
HYS72T128000HR-5-A	DIMM DDR2-400 1GB 128M*72 REG ECC 1.2"	INFINEON TECHNOLOGIES
M393T2950BZ0-CCC	DIMM DDR2-400 1GB 128M*72 REG ECC 1.2"	Samsung Semiconductor
MT18HTF12872Y-40EB3	DIMM DDR2-400 1GB 128M*72 REG ECC 1.2"	Micron Technology, Inc.
VL393T5663-D5S	DIMM DDR2-533 2GB 256M*72 X8 REG ECC LP	VIRTIIUM
VL393T5663-D5E	DIMM DDR2-533 2GB 256M*72 X8 REG ECC LP	VIRTIIUM
VL393T5663-D5F	DIMM DDR2-533 2GB 256M*72 X8 REG ECC LP	VIRTIIUM
VL393T2953-D5S	DIMM DDR2-533 1GB 128M*72 REG ECC 1.18"	VIRTIIUM

Memory should have the following characteristics:

- DDR2 400
- 1.8V only
- Single-sided or double-sided
- 1 layer of BGA on PCB side
- X4 or X8 configuration supported
- Serial Presence Detect (SPD) EEPROM
- 72-bit DIMMs only
- 1.2 inch maximum height



### WARNING



Because static electricity can cause damage to electronic devices, take the following precautions:

Keep the board in its anti-static package, until you are ready to install memory.

Wear a grounding wrist strap before removing the board from its package; this will discharge any static electricity that may have built up in your body.

Handle the board by the faceplate or its edges.

---

### 3.3.1 Installing Memory

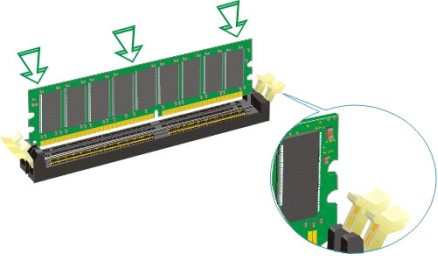
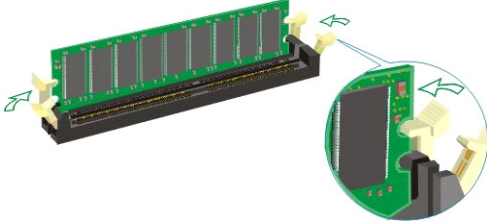
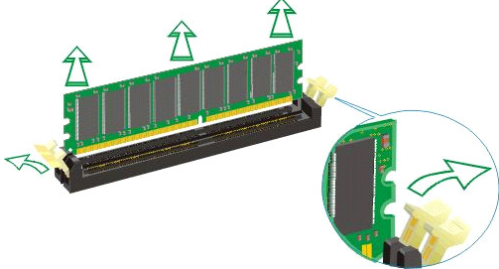







<p>On an anti-static plane, place the board so that you are facing the memory sockets</p>	
<p>Insert the memory module into any available socket, aligning the notches on the module with the socket's key inserts.</p>	
<p>Push down the memory module until the retaining clips on each side.</p>	
<p>Repeat these steps to populate the other socket.</p>	
<p>To remove a memory module from a socket, push sideways the retaining clips on each side of the socket, to release the module. Pull out the memory from the socket.</p>	

## 3.4 Onboard Interconnectivity and Indicators

### 3.4.1 Onboard Connectors and Headers

Description	Connector	Comments
CPU	J5	Second CPU
CPU	J6	First CPU. This CPU must always be present
RTM Connector	J7	RTM connector to connect to the RT8020
DDR-2 Memory Connectors	J8, J9, J10 & J11	4 angled memory sockets
XDP	J12	
USB 2.0 Connector	J13	
Serial Port	J14	
Telco Clock Connector & Fabric Interface	J17	
Daughter Card Connectors	J18 & J19	
AMC B1	J20	
Base Interface Connector	J21	
AMC B2	J23	
Power Connector	P1	

### 3.4.2 Front Plate Symbol Chart

Symbols Chart	
	Out Of Service
	Hot Swap
	Management (IPMI)
	Serial Port
<b>BI</b>	Base Interface
	User Defined
<b>+</b>	Healthy
	Reset
	USB
	Ethernet
<b>FI</b>	Fabric Interface
	Flash or SAS Drive

## 3.5 Board Hot Swap and Installation

Because of the high-density pinout of the hard-metric connector, some precautions must be taken when connecting or disconnecting a board to/from a backplane:

- 1 Rail guides must be installed on the enclosure to slide the board to the backplane.
- 2 Do not force the board if there is mechanical resistance while inserting the board.
- 3 Screw the frontplate to the enclosure to firmly attach the board to its enclosure.
- 4 Use extractor handles to disconnect and extract the board from its enclosure.



### WARNING

Always use a grounding wrist wrap before installing or removing the board from a chassis.



### 3.5.1 Installing the Card in the Chassis

To install a card in a chassis:

- 1 Remove the filler panel of the slot or see "Removing the Board" below.
- 2 Ensure the board is configured properly.
- 3 Carefully align the PCB edges in the bottom and top card guide.
- 4 Insert the board in the system until it makes contact with the backplane connectors.
- 5 Using both ejector handles, engage the board in the backplane connectors until both ejectors are locked.
- 6 Fasten screws at the top and bottom of the faceplate.

### 3.5.2 Removing the Board

If you would like to remove a card from your chassis please follow carefully these steps:

- 1 Unscrew the top and the bottom screw of the front panel.
- 2 Unlock the lower handle latch, depending on the software step, this may initiate a clean shutdown off the operating system.
- 3 Wait until the blue LED is fully ON, this mean that the hot swap sequence is ready for board removal.
- 4 Use both ejectors to disengage the board from the backplane.
- 5 Pull the board out of the chassis.

### 3.5.3 Installing an AMC

To install an AMC:

- 1 Remove the AMC filler panel.
- 2 Carefully engage the AMC into the card guide. Push the AMC until it fully mate with it's connector. Secure the AMC handle to the locking position.
- 3 In normal condition, the blue LED shall turn ON as soon as the AMC is fully inserted. It will turn OFF at the end of the hot swap sequence.

### 3.5.4 Removing an AMC

To remove an AMC:

- 1 Pull out the handle to unlock the AMC.
- 2 Wait for the blue LED to turn on.
- 3 Pull out the AMC using the handle.

### 3.5.5 Installing a RTM

To install a RTM:

- 1 Remove the filler panel of the slot.
- 2 Ensure the board is configured properly.
- 3 Carefully align the PCB edges in the bottom and top card guide.
- 4 Insert the board in the system until it makes contact with the CPU board.
- 5 Using both ejector handles, engage the board in the CPU board connectors until both ejectors are locked.
- 6 Fasten screws at the top and bottom of the faceplate.

### 3.5.6 Removing a RTM

To remove a RTM:

- 1 Unscrew the top and the bottom screw of the faceplate.
- 2 Unlock the lower handle latch.
- 3 Wait until the blue LED is fully ON, this mean that the hot swap sequence is ready for board removal.
- 4 Use both ejectors to disengage the board from the CPU board.
- 5 Pull the board out of the chassis.

# 4. Building an ATCA System

## 4.1 Building an ATCA System

The basic components needed to build an ATCA system include:

- 1 Chassis (which includes backplane, power supply or power entry modules, fans)
- 2 Base interface switches and optional fabric interface switches
- 3 Shelf manager controllers (ShMC)
- 4 One or more AT8020 or other ATCA node boards
- 5 Possibly some rear transition modules

Consult Kontron's web site for available chassis, switches and node boards.

See your system's manual for more details.



### 4.1.1 Backplane

The AT8020 is compliant to ATCA 3.0R1.0 spec. It can be used in a Dual Star or a Full Mesh configuration.

## 4.1.2 Rear-Panel I/O

This feature is intended to extend the I/O capabilities of the AT8020 to the rear of the enclosure using a RTM I/O.

The RTM I/O module gathers all the I/O signals of the CPU board and makes them easily accessible through standard headers and connectors located at the rear of enclosure.



### WARNING

Always use Kontron's RTM with your Kontron's board, if not permanent damage could occur.



## 4.1.3 External Storage Devices

The AT8020 supports external storage device through the SAS connector available on the RTM

## 4.1.4 Power Supply

The AT8020 expects two -48V feeds as per PICMG3.0R1.0. The AT8020 is fully working over a range of -38V to -72V as required by the specification.



### Note:

10W Management power can be lightly exceeded when the power feed is between -60V and -72V

## 4.1.5 Mechanical Keying and Alignment

Although ATCA systems are managed by electronic keying (E-Keying), mechanical features are also defined for keying and alignment of the front board, backplane and RTM.

Different angle positions are defined in the PICMG 3.0 specification and each rotation corresponds to a unique value.

ATCA backplanes and front boards A1/K1 (Alignment/Keying) values are 1/1, for a zero degree rotation. These values are mandatory for all ATCA boards.

However, the RTM keying is defined by the front board manufacturer. Currently, Kontron also uses the A2/K2 values of 1/1 in order to match the front CPU board to the RTM.

If unwanted mechanical matching ever happens in the field, E-Keying would prevent connection of such incompatible components, through the supervision of the Intelligent Platform Management Controller (IPMC).

# 5. Software Setup

## 5.1 AMI BIOS Setup Program

All relevant information for operating the board and connected peripherals is stored in the CMOS memory backed-up by a supercap or in the main BIOS flash. The latest if the default configuration.

### 5.1.1 Accessing the BIOS Setup Utility

The system BIOS (Basic Input Output System) provides an interface between the operating system and the hardware of the AT8020 SBC. It uses the AMI Setup program, a setup utility in flash memory that is accessed by pressing the <DELETE> key at the appropriate time during system boot. This utility is used to set configuration data in CMOS RAM.

To run the AMI Setup program incorporated in the ROM BIOS:

- Turn on or reboot the system.
- When you get the following messages, hit <DELETE> key (or F4 on Remote Keyboard) to enter SETUP.

AMIBIOS(C)2005 American Megatrends, Inc.

KONTRON AT8020

CPU : Intel(R) Xeon(TM) CPU @ 2.00GHz

Speed : 2.00 GHz Count : 2

Press DEL to run Setup (F4 on Remote Keyboard)

Press F12 if you want to boot from the network

Press F11 for BBS POPUP (F3 on Remote Keyboard)

(C) American Megatrends, Inc.

The main menu of the AMI BIOS CMOS Setup Utility appears on the screen.

BIOS Setup Utility					
Main	Advanced	Security	Boot	System Management	Exit
<b>System Overview</b>			Use [ENTER], [TAB] or [SHIFT-TAB] to select a field.		
<b>AMIBIOS</b>			Use [+] or [-] to configure system Time.		
BIOS Version		08.00.14			
Build Date		08/16/07			
BIOS ID		5004_300			
Boot Block Version		3.00			
FPGA Ver.		2.07			
Channel A1 Memory Size		1 GB			
Channel B1 Memory Size		1 GB			
Channel A2 Memory Size		1 GB			
Channel B2 Memory Size		1 GB	↔ Select Screen		
System Memory Speed		400 MHz	↑↓ Select Item		
System Memory		642 KB	+- Change Field		
Extended Memory		4192768 KB	Tab Select Field		
System Time		[16:56:04]	F1 General Help		
System Date		[08:08:2007]	F10 Save and Exit		
			ESC Exit		
v02.59 (C)Copyright 1985-2005, American Megatrends, Inc.					

Setup Default values provide optimum performance settings for all devices and system features.



**Note:**

The CMOS setup option described in this section is based on BIOS Version 3.00. The options and default settings may change in a new BIOS release.



**Note:**

When an asterisk(\*) is present in the menu this means that this menu is optional and it will be present only with certain options.



**CAUTION**

These parameters have been provided to give control over the system. However, the values for these options should be changed only if the user has a full understanding of the timing relationships involved.



## 5.1.2 Menu Bar

The Menu Bar at the top of the window lists these selections:

Menu Selection	Description
Main	Use this menu for basic system configuration.
Advanced	Use this menu to set the Advanced Features available on your system.
Security	Use this menu to configure Security features.
Boot	Use this menu to determine the booting device order.
System Management	Use this menu to set the System Management on your system.
Exit	Use this menu to choose Exits option.

Use the left and right arrows keys to make a selection.

### 5.1.2.1 Legend Bar

Use the keys listed in the legend bar on the bottom to make your selections or exit the current menu. The chart on the following page describes the legend keys and their alternates.

Key	Function
<F1>	General Help windows (see 4.1.2.2).
<Esc>	Exit this menu.
--> arrow keys	Select a different menu.
<Home> or <End>	Move cursor to top or bottom of window.
<->	Select the Previous Value for the field.
<+>	Select the Next Value for the field.
<F2> and <F3>	Change colors used in Setup.
<F7>	Discard the changes for all menus.
<F9>	Load the Optimal Default Configuration values for all menus.
<F10>	Save and exit.
<Enter>	Execute Command, display possible value for this field or Select the sub-menu.

To select an item, use the arrow keys to move the cursor to the field you want. Then use the plus-and-minus value keys to select a value for that field. To save value commands in the Exit Menu, save the values displayed in all menus.

To display a submenu, use the arrow keys to move the cursor to the submenu you want. Then press <Enter>. A pointer (?) marks all sub-menus.

### 5.1.2.2 Field Help Window

The help window on the right side of each menu displays the help text for the selected field.

It updates as you move the cursor to each field.

### 5.1.2.3 *General Help Windows*

Pressing <F1> on any menu brings up the General Help window that describes the legend keys and their alternates:

General Help	
↔	Select Screen
+ -	Change Option/Field
PGDN	Next Page
HOME	Go to Top of Screen
F2/F3	Change Colors
F10	Save and Exit
↑↓	Select Item
Enter	Go to Sub Screen
PGUP	Previous Page
END	Go to Bottom of Screen
F7	Discard Changes
F9	Load Optimal Defaults
ESC	Exit
[OK]	

### 5.1.3 Main Menu

Feature	Option	Help text
BIOS Version	X.YY.R X.YY.K	N/A
Build Date	X.YY	N/A
BIOS ID		N/A
Boot Block Version		N/A
FPGA Version		N/A
Channel A1 Memory Size	X KB/MB/GB	N/A
Channel B1 Memory Size	X KB/MB/GB	N/A
Channel A2 Memory Size	X KB/MB/GB	N/A
Channel B2 Memory Size	X KB/MB/GB	N/A
System Memory Speed	X MHz	N/A
System Memory	X KB	N/A
Extended Memory	X KB	N/A
System Time	HH:MM:SS	Use [+] or [-] to configure system time.
System Date	MM/DD/YYYY	Use [+] or [-] to configure system date.

### 5.1.4 Advances Menu

Feature	Option	Help text
Advanced Processor Configuration	N/A	N/A
IDE Configuration	N/A	N/A
ACPI Configuration	N/A	N/A
Event Log Configuration	N/A	N/A
Expansion ROM Configuration	N/A	N/A
PCI Express Configuration	N/A	N/A
USB Configuration	N/A	N/A
Advanced Chipset Control	N/A	N/A
MPS Revision	1.1 1.4	Multiprocessor specification revision level.

#### 5.1.4.1 *Advances Processor Configuration sub-menu*

Feature	Option	Help text
Physical Processors	2	N/A
Logical Processors	4	N/A
Processor Type	Sossaman	N/A
Processor 0 Speed	Varies	N/A
Processor 1 Speed	Varies	N/A

Feature	Option	Help text
FSB Speed	Varies	N/A
Processor 0 Microcode	CPUID: XXX Update Revision: XXXX	N/A
Processor 0 L2 Cache Size	2 MB	N/A
Processor 1 Microcode	CPUID: XXX Update Revision: XXXX	N/A
Processor 1 L2 Cache Size	2 MB	N/A
Processor Virtualization	Enabled Disabled	Enabled: Processor virtualization in use. Disabled: Processor virtualization not in use. Setting can only be changed after power ON. After a reset or a soft reboot, this option stay in grey and can not be changed.
SpeedStep	N/A	Configures SpeedStep technology.
Thermal Management	N/A	Configures thermal monitors.

#### 5.1.4.2 *SpeedStep Configuration sub-menu*

Feature	Option	Help text
SpeedStep	Maximum Speed Minimum Speed Variable Speed Fixed Speed Disabled	Maximum: CPU speed is set to maximum. Minimum: CPU speed is set to minimum. Variable: CPU speed is controlled by operating system Fixed: CPU speed is set to fixed value. Disabled: Default CPU speed is used.
Processor 0 Speed	1000 MHz (here all supported speeds between LFM and HFM as supported by Intel) 2000 MHz (2300 MHz later)	Minimum speed: 1000 MHz Maximum speed: 2000 MHz
Processor 0 Core 0	Enabled	N/A
Processor 0 Core 1	Enabled Disabled	Enabled: CMP is in use for processor 0 and processor 1 i.e. both cores are available for both processors. Disabled: CMP is not used for either processor.
Processor 1 Speed	1000 MHz (here all supported speeds between LFM and HFM as supported by Intel) 2000 MHz (2300 MHz later)	Minimum speed: 1000 MHz Maximum speed: 2000 MHz
Processor 1 Core 0	Enabled	N/A
Processor 1 Core 1	Enabled Disabled	N/A

### 5.1.4.3 Thermal Management sub-menu

Feature	Option	Help text
Thermal Monitor 1	Enabled Disabled	Enabled: TM1 in use. Disabled: TM1 not in use. Use only for testing purposes.
Thermal Monitor 2	Enabled Disabled	Enabled: TM2 in use. Disabled: TM2 not in use. Use only for testing purposes.
Digital Thermal Sensor	Enabled	Enabled: DTS for each core is in use.

### 5.1.4.4 IDE Configuration sub-menu

Feature	Option	Help text
IDE Configuration	Disabled P-ATA Only S-ATA Only P-ATA & S-ATA	Select IDE Mode. P-ATA Only: 4 P-ATA & 2 S-ATA S-ATA Only: 2 S-ATA P-ATA & S-ATA: 2 P-ATA & 2 S-ATA
Primary IDE Master	This is a sub-menu	While entering setup BIOS auto detects the presence of IDE devices. This displays the status of auto detection of IDE devices.
Primary IDE Slave	This is a sub-menu	While entering setup BIOS auto detects the presence of IDE devices. This displays the status of auto detection of IDE devices.
Secondary IDE Master	This is a sub-menu	While entering setup BIOS auto detects the presence of IDE devices. This displays the status of auto detection of IDE devices.
Secondary IDE Slave	This is a sub-menu	While entering setup BIOS auto detects the presence of IDE devices. This displays the status of auto detection of IDE devices.
Third IDE Master	This is a sub-menu	While entering setup BIOS auto detects the presence of IDE devices. This displays the status of auto detection of IDE devices.
Fourth IDE Master	This is a sub-menu	While entering setup BIOS auto detects the presence of IDE devices. This displays the status of auto detection of IDE devices.
Hard Disk Write Protect	Enabled Disabled	Disabled/Enabled device write protection. This will be effective only if device is accessed through BIOS.
IDE Detect Time Out	0, 5, 10, 15, 20, 25, 30, 35	Configures the time out value for detecting ATA/ATAPI device(s).

## 5.1.4.4.1 Primary IDE Master

Feature	Options	Description
Primary IDE Master	Device Vendor Size LBA Mode Block Mode PIO Mode Async DMA Ultra DMA S.M.A.R.T.	This is a list of modes and features supported by the drive, not how it is setup.
Type	Not installed Auto CD/DVD ARMD	Select the type of device connected to the system.
LBA/Large Mode	Disabled Auto	Disabled: Disables LBA Mode. Auto: Enables LBA Mode if the device supports it and the device is not already formatted with LBA Mode3 disabled
Block (Multi-Sector Transfer)	Disabled Auto	Disabled: the data transfer from and to the device occurs one sector at the time. Auto: the data transfer from and to the device occurs multiple sector at a time it the device supports it.
PIO Mode	Auto 0 1 2 3 4	Select PIO Mode.
DMA Mode	Auto SWDMA0 SWDMA1 SWDMA2 MWDMA0 MWDMA1 MWDMA2 UDMA0 UDMA1 UDMA2 UDMA3 UDMA4	Select DMA Mode. Auto: Auto detect SWDMA: SingleWordDMA MWDMA: MultiWordDMA UDMA: UltraDMA
32Bit Data Transfer	Disabled Enabled	Enable/Disabled 32-bit Data Transfer.

## 5.1.4.4.2 Primary IDE Slave

Feature	Options	Description
Primary IDE Master	Device Vendor Size LBA Mode Block Mode PIO Mode Async DMA Ultra DMA S.M.A.R.T.	This is a list of modes and features supported by the drive, not how it is setup.
Type	Not installed Auto CD/DVD ARMD	Select the type of device connected to the system.
LBA/Large Mode	Disabled Auto	Disabled: Disables LBA Mode. Auto: Enables LBA Mode if the device supports it and the device is not already formatted with LBA Mode3 disabled
Block (Multi-Sector Transfer)	Disabled Auto	Disabled: the data transfer from and to the device occurs one sector at the time. Auto: the data transfer from and to the device occurs multiple sector at a time it the device supports it.
PIO Mode	Auto 0 1 2 3 4	Select PIO Mode.
DMA Mode	Auto SWDMA0 SWDMA1 SWDMA2 MWDMA0 MWDMA1 MWDMA2 UDMA0 UDMA1 UDMA2 UDMA3 UDMA4	Select DMA Mode. Auto: Auto detect SWDMA: SingleWordDMA MWDMA: MultiWordDMA UDMA: UltraDMA
32Bit Data Transfer	Disabled Enabled	Enable/Disabled 32-bit Data Transfer.

## 5.1.4.4.3 Secondary IDE Master

Feature	Options	Description
Secondary IDE Master	Device Vendor Size LBA Mode Block Mode PIO Mode Async DMA Ultra DMA S.M.A.R.T.	This is a list of modes and features supported by the drive, not how it is setup.
Type	Not installed Auto CD/DVD ARMD	Select the type of device connected to the system.
LBA/Large Mode	Disabled Auto	Disabled: Disables LBA Mode. Auto: Enables LBA Mode if the device supports it and the device is not already formatted with LBA Mode3 disabled
Block (Multi-Sector Transfer)	Disabled Auto	Disabled: the data transfer from and to the device occurs one sector at the time. Auto: the data transfer from and to the device occurs multiple sector at a time it the device supports it.
PIO Mode	Auto 0 1 2 3 4	Select PIO Mode.
DMA Mode	Auto SWDMA0 SWDMA1 SWDMA2 MWDMA0 MWDMA1 MWDMA2 UDMA0 UDMA1 UDMA2 UDMA3 UDMA4	Select DMA Mode. Auto: Auto detect SWDMA: SingleWordDMA MWDMA: MultiWordDMA UDMA: UltraDMA
32Bit Data Transfer	Disabled Enabled	Enable/Disabled 32-bit Data Transfer.

## 5.1.4.4.4 Secondary IDE Slave

Feature	Options	Description
Secondary IDE Slave	Device Vendor Size LBA Mode Block Mode PIO Mode Async DMA Ultra DMA S.M.A.R.T.	This is a list of modes and features supported by the drive, not how it is setup.
Type	Not installed Auto CD/DVD ARMD	Select the type of device connected to the system.
LBA/Large Mode	Disabled Auto	Disabled: Disables LBA Mode. Auto: Enables LBA Mode if the device supports it and the device is not already formatted with LBA Mode3 disabled
Block (Multi-Sector Transfer)	Disabled Auto	Disabled: the data transfer from and to the device occurs one sector at the time. Auto: the data transfer from and to the device occurs multiple sector at a time it the device supports it.
PIO Mode	Auto 0 1 2 3 4	Select PIO Mode.
DMA Mode	Auto SWDMA0 SWDMA1 SWDMA2 MWDMA0 MWDMA1 MWDMA2 UDMA0 UDMA1 UDMA2 UDMA3 UDMA4	Select DMA Mode. Auto: Auto detect SWDMA: SingleWordDMA MWDMA: MultiWordDMA UDMA: UltraDMA
32Bit Data Transfer	Disabled Enabled	Enable/Disabled 32-bit Data Transfer.

## 5.1.4.4.5 Third IDE Master

Feature	Options	Description
Third IDE Master	Device Vendor Size LBA Mode Block Mode PIO Mode Async DMA Ultra DMA S.M.A.R.T.	This is a list of modes and features supported by the drive, not how it is setup.
Type	Not installed Auto CD/DVD ARMD	Select the type of device connected to the system.
LBA/Large Mode	Disabled Auto	Disabled: Disables LBA Mode. Auto: Enables LBA Mode if the device supports it and the device is not already formatted with LBA Mode3 disabled
Block (Multi-Sector Transfer)	Disabled Auto	Disabled: the data transfer from and to the device occurs one sector at the time. Auto: the data transfer from and to the device occurs multiple sector at a time it the device supports it.
PIO Mode	Auto 0 1 2 3 4	Select PIO Mode.
DMA Mode	Auto SWDMA0 SWDMA1 SWDMA2 MWDMA0 MWDMA1 MWDMA2 UDMA0 UDMA1 UDMA2 UDMA3 UDMA4	Select DMA Mode. Auto: Auto detect SWDMA: SingleWordDMA MWDMA: MultiWordDMA UDMA: UltraDMA
32Bit Data Transfer	Disabled Enabled	Enable/Disabled 32-bit Data Transfer.

## 5.1.4.4.6 Fourth IDE Master

Feature	Options	Description
Fourth IDE Master	Device Vendor Size LBA Mode Block Mode PIO Mode Async DMA Ultra DMA S.M.A.R.T.	This is a list of modes and features supported by the drive, not how it is setup.
Type	Not installed Auto CD/DVD ARMD	Select the type of device connected to the system.
LBA/Large Mode	Disabled Auto	Disabled: Disables LBA Mode. Auto: Enables LBA Mode if the device supports it and the device is not already formatted with LBA Mode3 disabled
Block (Multi-Sector Transfer)	Disabled Auto	Disabled: the data transfer from and to the device occurs one sector at the time. Auto: the data transfer from and to the device occurs multiple sector at a time it the device supports it.
PIO Mode	Auto 0 1 2 3 4	Select PIO Mode.
DMA Mode	Auto SWDMA0 SWDMA1 SWDMA2 MWDMA0 MWDMA1 MWDMA2 UDMA0 UDMA1 UDMA2 UDMA3 UDMA4	Select DMA Mode. Auto: Auto detect SWDMA: SingleWordDMA MWDMA: MultiWordDMA UDMA: UltraDMA
32Bit Data Transfer	Disabled Enabled	Enable/Disabled 32-bit Data Transfer.

### 5.1.4.5 *ACPI Configuration sub-menu*

Feature	Option	Help text
ACPI Version Features	ACPI v1.0	Enabled: RSDP pointer to 64-bit Fixed System Description Tables. Different ACPI version has some addition.
	ACPI v2.0	
	ACPI v3.0	
ACPI APIC Support	Enabled	Enabled: ACPI APIC table support.
	Disabled	Disabled: ACPI APIC table not supported.
Headless Mode	Enabled	Enabled: Headless operation mode through ACPI supported.
	Disabled	Disabled: Headless operation mode through ACPI not supported.

### 5.1.4.6 Event Log Configuration sub-menu

Feature	Option	Help text
Event Log capacity	Space Available No Space	Shows if space is available in the Event Log for new log events.
Event Logging	Enabled Disabled	Enabled: Event Log is used. Disabled: Event Log is not used. If this option is disabled no SEL events are available from this blade!
View Event Log	Enter	View all unread events in the Event Log.
Mark Events as read	Enter	Mark all unread events as read in the Event Log.
Clear all Event Logs	Enter	Discard all events in the Event Log.
DRAM Data Integrity Mode	ECC Non-ECC	ECC: x4 Chip-Fail ECC used in dual channel mode. 72-bit ECC used in single channel mode. Non-ECC: Use only for testing purposes.
ECC Event Logging	Enabled Disabled	Enabled: ECC event logging enabled. Disabled: ECC event logging disabled.
ECC Error Reporting	Correctable Uncorrectable Both Disabled	"Correctable" ECC for testing purposes. "Uncorrectable" ECC errors reported. "Both" ECC errors for testing purposes. Disabled: ECC errors not reported.
Hub Interface Event Logging	Enabled Disabled	Enabled: Hub interface event logging enabled. Disabled: Hub interface event logging disabled.
System Bus Event Logging	Enabled Disabled	Enabled: System bus event logging enabled. Disabled: System bus event logging disabled.
Memory Buffer Event Logging	Enabled Disabled	Enabled: Memory buffer event logging enabled. Disabled: Memory buffer event logging disabled.
PCI Error Logging	Enabled Disabled	Enabled: PCI error event logging enabled. Disabled: PCI error event logging disabled.
PCI Express Error Logging	Enabled Disabled	Enabled: PCI-E error event logging enabled. Disabled: PCI-E error event logging disabled.
PCI Express Error Masking	N/A	N/A

### 5.1.4.7 PCI Express Error Masking sub-menu

Feature	Option	Help text
Mask duplicate Errors	Yes No	Yes: Mask duplicate errors found in successive SMI interrupts No: Duplicate errors found in successive SMI interrupts are not masked. Note: Duplicate errors in single SMI interrupt are always masked.
Mask Unsupported Requests	Yes No	Yes: Unsupported request errors can be masked. No: Default mask is used.

### 5.1.4.8 Expansion ROM Configuration sub-menu

Feature	Option	Help text
Ethernet BI Expansion ROM	Enabled Disabled	Enabled: Initializes base interface PXE expansion ROM. Disabled: Base interface PXE expansion ROM not used. If disabled, remote LAN boot via BI is not available to boot the system!
Ethernet FI Expansion ROM	Enabled Disabled	Enabled: Initializes fabric interface PXE expansion ROM. Disabled: Fabric interface PXE expansion ROM not used. If disabled, remote LAN boot via FI is not available to boot the system!
Ethernet MEZ Expansion ROM	Enabled Disabled	Enabled: Initializes mezzanine PXE expansion ROM. Disabled: Mezzanine PXE expansion ROM not used. If disabled, remote LAN boot is not available to boot the system!
Ethernet 82551QM Expansion ROM	Enabled Disabled	Enabled: Initializes mezzanine PXE expansion ROM. Disabled: Mezzanine interface PXE expansion ROM not used. If disabled, remote LAN boot is not available to boot the system!
FC / SAS Expansion ROM	Enabled Disabled	Enabled: Initializes FC / SAS expansion ROM. Disabled: FC / SAS expansion ROM not used. If disabled, any FC / SAS devices attached to the system are not available to boot the system!
AMC Slot 1 Expansion ROM	Enabled Disabled	Enabled: Initializes AMC slot 1 expansion ROM. Disabled: AMC slot 1 expansion ROM not used.
AMC Slot 2 Expansion ROM	Enabled Disabled	Enabled: Initializes AMC slot 2 expansion ROM. Disabled: AMC slot 2 expansion ROM not used.

### 5.1.4.9 PCI Express Configuration sub-menu

Feature	Option	Help text
Hot Plug Support - AMC B1	Enabled Disabled	Enabled: Set PCI Express Hot Plug capability. Disabled: Hot Plug is not available on this port.
Hot Plug Support - AMC B2	Enabled Disabled	Enabled: Set PCI Express Hot Plug capability. Disabled: Hot Plug is not available on this port.
Actual Clock Mode State	SSC Non-SSC	N/A
Clock Mode Setting	SSC Non-SSC	Select the PCI Express Clock Mode. Warning! To change the PCI Express Clock Mode, you need to re-insert the blade into the shelf. AMC ekeying use this setting to allow "SSC" or "non-SSC" PCI Express AMC.

### 5.1.4.10 USB Configuration sub-menu

Feature	Option	Help text
USB Devices Enabled:	N/A	
USB 2.0 Controller Mode	FullSpeed HiSpeed	FullSpeed: 12 Mbps HiSpeed: 480 Mbps
BIOS EHCI Hand-Off	Enabled Disabled	Enabled: EHCI hand-off support enabled. Disabled: EHCI hand-off support disabled.
USB Mass Storage Device Configuration (only present if USB Mass Storage detected)	N/A	Configure the USB Mass Storage Class Devices.

### 5.1.4.11 USB Mass Storage Device Configuration sub-menu

Feature	Option	Help text
USB Mass Storage Reset Delay	10 Sec 20 Sec 30 Sec 40 Sec	N/A
Device # 1-6	N/A	N/A
Emulation Type (For each device)	Auto Floppy Forced FDD Hard Disk CDROM	If Auto, USB devices less than 530MB will be emulated as Floppy and remaining as hard drive. Forced FDD option can be used to force a HDD formatted drive to boot as FDD.

### 5.1.4.12 Advanced Chipset Control sub-menu

Feature	Option	Help text
Memory Remapping	Enabled Disabled	Enabled: Allows remapping of overlapped PCI memory above the total physical memory. Requires PAE support in OS. Disabled: Memory remapping not allowed.
Memory Mirroring / Sparing	Mirroring Sparing Disabled	Mirroring: Memory mirroring feature enabled if supported. Sparing: Memory sparing feature enabled if supported by memory configuration. Disabled: Memory RAS features disabled.
DMA Controller	Enabled Disabled	Enabled: DMA controller enabled. Disabled: DMA controller disabled.
DDR2 Refresh	3.9 $\mu$ S 7.8 $\mu$ S Auto	Allows override selection of the DDR2 refresh rate for normal operation.
Spread Spetrum Clocking Mode	Enabled Disabled	Enabled: Allows setting of Clock Spread Spectrumfor EMI control. Disabled: Denies setting of Clock Spread Spectrum for EMI control.

## 5.1.5 Security Menu

Feature	Option	Help text
Supervisor Password	Installed Not Installed	Indicates the status of the supervisor password.
User Password	Installed Not Installed	Indicates the status of the user password.
Set Supervisor Password	Enter	Install or change the supervisor password. Only the first 5 characters will be used.
Set User Password	Enter	Install or change the user password. Only the first 5 characters will be used.
Clear User Password	Enter	Clears user password.
User Access Level	No Access View Only Limited Full Access	Controls access to the setup utility. No Access: Prevents user access. View only: allows read only user access. Limited: Allows limited fields to be changed. Full Access: Allows unlimited user access.
Execute Disable Bit	Enabled Disabled	Enabled: Allows processor to prevent application code access to certain memory areas. Needs supporting operating system. Disabled: No restrictions to application code memory area access by processor.

## 5.1.6 Boot Menu

Feature	Option	Help text
Boot Settings Configuration	N/A	Configure Settings during System Boot.
Boot Device Priority	N/A	Specifies the priority of the available boot sources.
Hard Disk Drives	N/A	Lists available hard disk drives in priority order.
Removable Drives	N/A	Lists available removable disk drives in priority order.
CD / DVD Drives	N/A	Lists available CD /DVD drives in priority order.
USB Drives	N/A	Lists available USB drives in priority order.
Network Drives	N/A	Lists available network drives in priority order.
Other Drives	N/A	Specifies the Lists available other drives in priority order.

### 5.1.6.1 *Boot Settings Configuration sub-menu*

Feature	Option	Help text
Quick Boot Mode	Enabled Disabled	Enabled: Allows skipping the memory tests during a cold boot. Disabled: Allows the extended memory test to be executed during a cold boot.
Extended Memory Test	Enabled Disabled	Enabled: Extended memory test is applicable when Quick Boot is disabled and a cold reset occurs. Disabled: Extended memory test is not performed in a reset.

### 5.1.6.2 *Boot Device Priority sub-menu*

Feature	Option	Help text
1 <sup>st</sup> Boot Device	Type: Boot device	Specifies the boot sequence from the available devices. A device enclosed in parenthesis has been disabled in the corresponding type menu.
...		
N <sup>th</sup> Boot Device	Type: Boot device	Specifies the boot sequence from the available devices. A device enclosed in parenthesis has been disabled in the corresponding type menu.

### 5.1.6.3 *Hard Disk, removable, CD/DVD, USB, Network and other drives sub-menu*

Feature	Option	Help text
1st Drive	Varies	Specifies the boot priority of the available devices. Select the boot device with UpArrow or DownArrow key. Press Enter to set the selection as the intended boot device.
...		
Nth Drive	Varies	Specifies the boot priority of the available devices. Select the boot device with UpArrow or DownArrow key. Press Enter to set the selection as the intended boot device.

## 5.1.7 System Management Menu

NOTE: Above example is to be updated with "Set LAN Configuration"

Feature	Option	Help text
Remote Access Configuration	N/A	N/A
Set LAN Configuration	N/A	IPMI over LAN (and Serial Over LAN)
Watchdog Timers	N/A	N/A
System Information	N/A	N/A

### 5.1.7.1 *Remote Access Configuration sub-menu*

Feature	Option	Help text
Serial Port Number	COM1 COM2	Select serial port for console redirection.
Serial Port 1 I/O address	3F8/IRQ4	Hardware address of the COM 1 port.
Serial Port 2 I/O address	2F8/IRQ3	Hardware address of the COM 2 port.
Baud Rate	9.6 KB 19.2 KB 38.4 KB 57.6 KB 115.2 KB	Select serial port Baud rate.

Feature	Option	Help text
Data Bits	7 8	Select the number of data bits in each transmitted or received serial character.
Parity	Even Odd None	Select if parity bit is generated (transmit data) or checked (receive data) between the last data word bit and stop bit of the serial data.
Stop Bits	1 2	Select the number of stop bits transmitted and received in each serial character.
Flow Control	Hardware Software None	Select flow control for console redirection.
Terminal Type	ANSI VT100 VTUTF8	Select the type of console emulation used.
Terminal Size	80x24	N/A
Terminal Display Mode	Normal Mode Recorder Mode	Select terminal display mode.
BIOS Printouts	Enabled Disabled	Select if BIOS POST messages are duplicated in a separate reserved memory region for OS examination.

### 5.1.7.2 Set LAN Configuration Sub-menu

Feature	Option	Help text
Channel Number	01	Enter Channel Number for SET LAN Config Command. Proper value below 16.
	02	
Channel Status	Valid or Invalid (display only)	
IP Address	N/A	Enter for IP Address Configuration.
MAC Address	N/A	Enter for MAC Address Configuration.
Subnet Mask	N/A	Enter for Subnet Mask Configuration.
Gateway Address	N/A	Enter for Gateway IP Address Configuration.
Active LAN Channel Number	Disabled	Enter Active LAN Channel Number for Set LAN Configuration Command. Only one LAN Channel can be activated.
	01	
	02	
	Both	

### 5.1.7.3 IP Configuration sub-menu

Feature	Option	Help text
LAN Parameter Selector	03	N/A
Channel Number	01	Enter Channel Number for SET LAN Config Command. Proper value below 16.
	02	
Channel Status	Valid or Invalid (display only)	N/A
IP Address	xxx.xxx.xxx.xxx	Enter IP Address in decimal in the form of XXX.XXX.XXX.XXX (XXX less than 256 and in decimal only).
Current IP Address	xxx.xxx.xxx.xxx	N/A

### 5.1.7.4 MAC Address Configuration sub-menu

Feature	Option	Help text
LAN Parameter Selector	05	N/A
Channel Number	01	Enter Channel Number for SET LAN Config Command. Proper value below 16.
	02	
Channel Status	Valid or Invalid (display only)	N/A
Current MAC Address	xx.xx.xx.xx.xx.xx (display only)	N/A

### 5.1.7.5 Subnet Mask Configuration sub-menu

Feature	Option	Help text
LAN Parameter Selector	06	N/A
Channel Number	01 02	Enter Channel Number for SET LAN Config Command. Proper value below 16.
Channel Status	Valid or Invalid (display only)	N/A
Subnet Mask	xxx.xxx.xxx.xxx	Enter Subnet Mask in decimal in the form of XXX.XXX.XXX.XXX (XXX less than 256 and in decimal only).
Current Subnet Mask	xxx.xxx.xxx.xxx	N/A

### 5.1.7.6 Gateway Address Configuration sub-menu

Feature	Option	Help text
LAN Parameter Selector	12	N/A
Channel Number	01 02	Enter Channel Number for SET LAN Config Command. Proper value below 16.
Channel Status:	Valid or Invalid (display only)	N/A
Gateway Address	xxx.xxx.xxx.xxx	Enter Gateway IP Address in decimal in the form of XXX.XXX.XXX.XXX (XXX less than 256 and in decimal only).
Current Gateway Address:	xxx.xxx.xxx.xxx	N/A

### 5.1.7.7 Watchdog Timer sub-menu

Feature	Option	Help text
BIOS POST Timeout	0	Select the BIOS POST IPMI HW watchdog timeout value.
	60	
	120	
	150	
	300	
	600	
BIOS POST Action	No Action Hard Reset Power Down Power Cycle	Select which action to take when the BIOS POST IPMI HW watchdog expires.
OS Load Timeout	0	Select the OS Load IPMI HW watchdog timeout value. Set to 0 to disable watchdog.
	60	
	120	
	150	
	300	
OS Load Action	600	Select which action to take when the OS Load IPMI HW watchdog expires.
	No Action	
	Hard Reset	
	Power Down Power Cycle	

### 5.1.7.8 System Information sub-menu

Feature	Option	Help text
Board Product Name	AT8020	N/A
Board Vendor	Kontron	N/A
Board Serial Number	Varies	N/A
Board Part Number	Varies	N/A
Chassis Slot	1..16	N/A
FWH In Use	Primary Secondary	Display Only
IPMI Device and FW Info	N/A	N/A

### 5.1.7.9 IPMI Device and FW Info sub-menu

Feature	Option	Help text
IPMI Version	1.5	N/A
IPMI Device ID	Varies	N/A
IPMI Device Revision	Varies	N/A
IPMI Firmware Version	Varies	N/A
SDR Revision	Varies	Display Only

## 5.1.8 Exit Menu

Feature	Option	Help text
Save Changes and Exit	N/A	Exit system setup after saving the changes. F10 key can be used for this operation.
Discard Changes and Exit	N/A	Exit system setup without saving any changes. ESC key can be used for this operation.
Load Optimal Defaults	N/A	Load Optimal Default values for all the setup questions. F9 key can be used for this operation.
Discard Changes	N/A	Discards changes done so far to any of the setup questions. F7 key can be used for this operation.
Exit & Update BIOS	N/A	Force BIOS recovery mode on next system reset.
Exit & Execute BIOS swap	N/A	Swap BIOS FWH without saving any changes.

## 5.2 Boot Utilities

AMI Boot Utilities are: Boot Menu POP-UP

Boot Menu POP-UP is a boot screen that displays a selection of boot devices from which you can boot your operating system.

### 5.2.1 Pressing <Del> (or <F4> from a Console Redirection terminal)

Pressing < Del > (or <F4> from a Console Redirection terminal) during POST enters Setup.

### 5.2.2 Pressing <F11> (or <F3> from a Console Redirection terminal)

Pressing <F11> (or <F3> from a Console Redirection terminal) displays the Boot Menu POP-UP with these options:

- 1 Load the operating system from a boot device of your choice.
- 2 Exit the Boot Menu POP-UP (with <ESC>) and load the operating system from the boot devices in the order specified in Setup.

### 5.2.3 BOOT Menu POP-UP

The BOOT Menu POP-UP expands your boot options by letting you choose your boot device, which could be a hard disk, floppy disk, CDRom, Flash Disk, SCSI or LAN. You can select your boot device in Setup, or you can choose a different device each time you boot during POST by selecting your boot device in the Boot device <F11> (or <F3> from a Console Redirection terminal).

## 5.3 Console Redirection (VT100 Mode)

The VT100 operating mode allows remote setup of the board. This configuration requires a remote terminal that must be connected to the board through a serial communication link.

### 5.3.1 Requirements

The terminal should emulate a VT100 or an ANSI terminal. Terminal emulation programs such as Telix®, HyperTerminal(Windows), minicom(Linux) or ProComm®(Windows) can also be used.

### 5.3.2 Running Without a Terminal

The board can boot up without a screen or terminal attached. If the speed is set to Auto and no terminal is connected, the speed is set to 115,200 bauds.

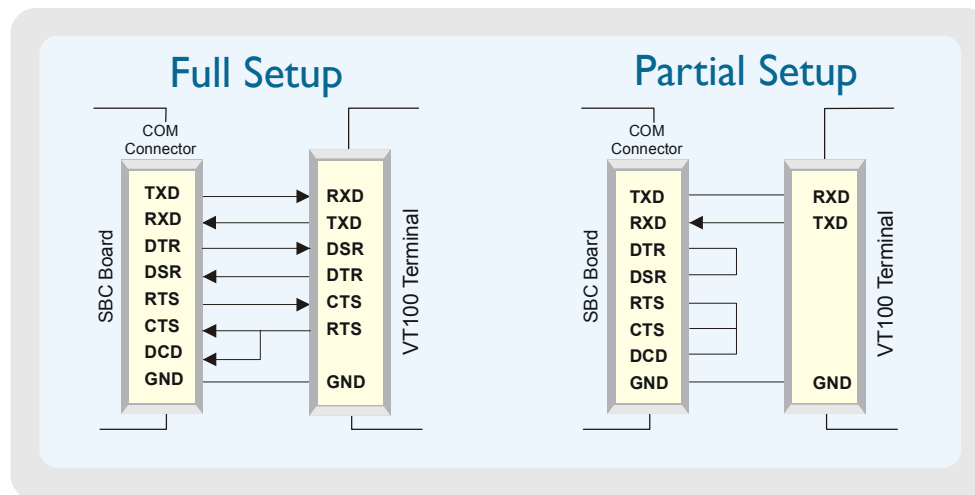

#### Note:

Refer to "Serial Port 1 (J5)" section for connector location and pinout.

### 5.3.3 ANSI and VT100 Keystroke Mapping

Up	<ESC>[A
Down	<ESC>[B
Right	<ESC>[C
Left	<ESC>[D
Home	<ESC>[H
End	<ESC>[K
F1	<ESC>OP
F2	<ESC>OQ
F3	<ESC>OR
F4	<ESC>OT

### 5.3.4 VT-UTF8 Keystroke Mapping

The following "escape sequences" are defined in the "Conventions for Keys Not in VT100 Terminal Definition and ASCII Character Set" section of "Standardizing Out-of-Band Management Console Output and Terminal Emulation (VT-UTF8 and VT100+)", available for download at [microsoft.com](http://microsoft.com).

F1 Key	<ESC>1
F2 Key	<ESC>2
F3 Key	<ESC>3
F4 Key	<ESC>4
F5 Key	<ESC>5
F6 Key	<ESC>6
F7 Key	<ESC>7
F8 Key	<ESC>8
F9 Key	<ESC>9
F10 Key	<ESC>0
F11 Key	<ESC>!
F12 Key	<ESC>@
Alt Modifier	<ESC>^A
Control Modifier	<ESC>^C
Home Key	<ESC>h
End Key	<ESC>k
Insert Key	<ESC>+
Delete Key	<ESC>-
Page Up Key	<ESC>?
Page Down Key	<ESC>/

These "escape sequences" are supported by VT-UTF8 compliant terminal connections, such as Windows Server 2003 Emergency Management Services (EMS).

AMIBIOS8 Serial Redirection supports these key sequences under two configurations:

- "Terminal Type" setup question is set to "VT-UTF8"
- "Terminal Type" setup question is set to "VT100" or "ANSI" and "VTUTF8 Combo Key Support" setup question is set to "Enabled"

## 5.4 Installing Drivers

### 5.4.1 SAS Drivers

Various drivers are provided for different operating systems and software. To install a driver, use the Setup program located on the CD-ROM (provided with your board).

### 5.4.2 Ethernet Drivers

Various drivers are provided for different operating systems and software. To install a driver, use the Setup program located on the CD-ROM (provided with your board).

### 5.4.3 Other Drivers

For other operating system drivers and installation instructions or for more information, visit our Web site at [www.kontron.com](http://www.kontron.com) or our FTP site at [ftp.kontron.ca/support/](ftp://ftp.kontron.ca/support/) or you may also contact Kontron's Technical Support department.

# A. Memory & I/O Maps

## A.1 Memory Mapping

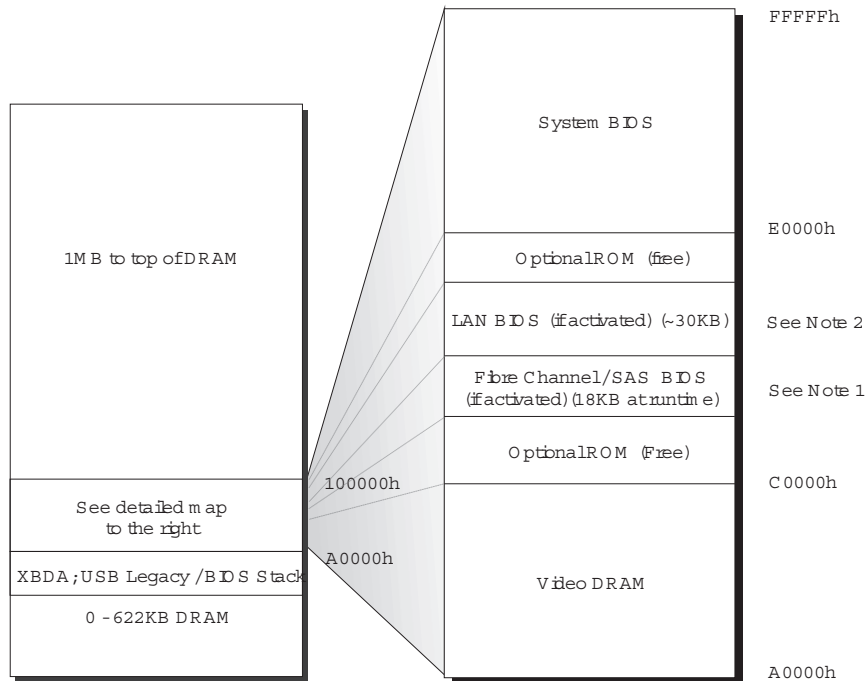

Note 1 : LAN BIOS address may vary

Note 2 : Fibre Channel/SAS BIOS address may vary.  
Size is only 2KB if no device.

Address	Function
00000-9B7FF	0-622 KB DRAM
9B800-9FFFF	622KB - 640 KB XBDA; USB Legacy / BIOS Stack
A0000-BFFFF	Video DRAM
C0000-DBFFF	Optional ROM (Free) LAN BIOS around 30KB if activated, address may vary External Fiber Channel BIOS 18KB-64KB , address may vary
E0000-FFFFF	System BIOS
100000-PCI Memory	DRAM available

## A.2 I/O Mapping

Address	Optional Address	Function
000-01F		DMA Controller 1
020-03F		Interrupt Controller 1
040-05F		Timer
060-06F		Keyboard
070-07F		Real-time clock
080-09F		DMA Page Register
0A0-0BF		Interrupt Controller 2
0C0-0DF		DMA Controller 2
0F0-0F1, 0F8-0FF		Math Coprocessor
1F0-1F7, 3F6		Primary IDE
170-177, 376		Secondary IDE
378-37F		Parallel Port (Used as PLD POD)
3F8-3FF (COM1)	2F8-2FF (COM2)	Serial Port 1 (COM1 by default)
2F8-2FF (COM2)	3F8-3FF (COM1)	Serial Port 2 (COM2 by default)
400-9FF		Chipset Reserved
A00-A1F		Kontron Registers (on-board)
B00-0FFF		Chipset Reserved

## A.3 PCI IDSEL and Device numbers

### A.3.1 All configurations

BUS#	DEV#	V. ID	D. ID	Funct. #	Description	PCI Description
0	0	8086h	3590h	0	E7520 - Memory Controller Hub	Bridge, host-bridge, multi-function
0	0	8086h	3591h	1	E7520 - Memory Error Reporting	Bridge, host-bridge, multi-function
0	1	8086h	3594h	0	E7520 - DMA Controller	System peripheral, non-specific, single-function
0	2	8086h	3595h	0	E7520 - Host-to-PCI Express A Bridge (x8 or x4)	Bridge, PCI-to-PCI, single-function, type 1 header
0	3	8086h	3596h	0	E7520 - Host-to-PCI Express A1 Bridge (x4 only)	Bridge, PCI-to-PCI, single-function, type 1 header
0	4	8086h	3597h	0	E7520 - Host-to-PCI Express B Bridge (x8 or x4) - (Support Hot-Plug)	Bridge, PCI-to-PCI, single-function, type 1 header
0	5	8086h	3598h	0	E7520 - Host-to-PCI Express B1 Bridge (x4 only)	Bridge, PCI-to-PCI, single-function, type 1 header
0	6	8086h	3599h	0	E7520 - Host-to-PCI Express C Bridge (x8 or x4) - (Support Hot-Plug)	Bridge, PCI-to-PCI, single-function, type 1 header
0	7	8086h	359Ah	0	E7520 - Host-to-PCI Express C1 Bridge (x4 only)	Bridge, PCI-to-PCI, single-function, type 1 header
0	7	8086h	359Bh	0	E7520 - Extended Configuration Registers	
0	28	8086h	25Aeh	0	i6300ESB ICH - HUB Interface to PCI-X Bridge	
0	29	8086h	25A9h	0	i6300ESB ICH - USB UHCI Controller #1	
0	29	8086h	25Aah	1	i6300ESB ICH - USB UHCI Controller #2	
0	29	8086h	25Abh	4	i6300ESB ICH - Watchdog Controller	
0	29	8086h	25Ach	5	i6300ESB ICH - IOAPIC bus B	
0	29	8086h	25Adh	7	i6300ESB ICH - USB EHCI Controller	
0	30	8086h	25A1h	0	i6300ESB ICH - HUB Interface to PCI Bridge	
0	31	8086h	25A2h	0	i6300ESB ICH - LPC Interface	
0	31	8086h	25A1h	1	i6300ESB ICH - IDE Controller	
0	31	8086h	25A3h	2	i6300ESB ICH - Serial-ATA Controller	
0	31	8086h	25A4h	3	i6300ESB ICH - SMBus Controller	
1	1	8086h	1209h	0	Intel Corporation 8255xLR / 82551IT Fast Ethernet Controller	Ethernet Controller
3	0	8086h	105Eh	0	Intel Corporation 82571EB Gigabit Ethernet Controller (rev 06)	Ethernet Controller

BUS#	DEV#	V. ID	D. ID	Funct. #	Description	PCI Description
3	0	8086h	105Eh	1	Intel Corporation 82571EB Gigabit Ethernet Controller (rev 06)	Ethernet Controller
4	0	8086h	1060h	0	Intel Corporation 82571EB Gigabit Ethernet Controller (rev 06)	Ethernet Controller
4	0	8086h	1060h	1	Intel Corporation 82571EB Gigabit Ethernet Controller (rev 06)	Ethernet Controller
5	0	1000h	0056h	0	LSI Logic / Symbios Logic SAS1064E PCI-Express Fusion-MPT SAS (rev 02)	SCSI Storage Controller
5	0	1000h	0056h	1		Ethernet Controller
6	0	8086h	1060h	1	Intel Corporation 82571EB Gigabit Ethernet Controller (rev 06)	Ethernet Controller
6	0	8086h	1060h	1	Intel Corporation 82571EB Gigabit Ethernet Controller (rev 06)	Ethernet Controller

# B. Kontron Extension Registers

## B.1 FPGA/CPLD Registers Definition

Unused bits are reserved. To insure compatibility with other products and upgrades to this product, do not modify unused bits. Bits marked NU are not used on this board. Writing to such bit does nothing and reading is undefined, either 0 or 1 may be returned.

Legend:

Symbol	Signification
U	Unchanged (stay unchanged after reset)
X	Not Defined (bit not used on this board)
NU	Not Used

## B.2 Sossaman Addressing Space

The following ranges will be used on Kontron Canada ATCA boards:

- I/O 0080-0081h for 16-bit postcodes
- I/O 0A00-0A1Fh to reserve permanently 32 locations in I/O space for on-board resources
- I/O 0378-037Ah hidden legacy LPT port for Xilinx JTAG programmer

Not all those I/O locations are used, but the LPC bridge will answer the cycle in zero wait-state.

### B.2.1 Summary of On-board Registers

Those registers are physically implemented in the AT8020 FPGA.

Address	Function
80-81h	Postcodes
A00h	Version
A01h	Debug LED and Mfg flag
A02h	Firmware Update Manager (FWUM) related
A03h	BIOS to IPMC Mailbox
A04h	Development features (for in-house use only)
A05h	LED configuration and RTM test
A06h	Jumpers and PCB version
A07h	BOM version (component straps)
A08h	T2604 Flash control
A09h	RTM PLD Version
A0Ah	Reset History
A0Bh	Mezzanine presence and identification
A10-A1Fh	Reserved for future ATCA boards
378-37Ah*	Legacy LPT port for FPGA upgrade exclusively.
600-7FFh	Reserved for customer extension

\* in case of hardware conflict, possible alternate addresses are:

- LPT1: 378-37Ah
- LPT2: 278-27Ah
- LPT3: 3BC-3BFh

## B.2.2 80-81h: Postcodes

Address	Action	D7	D6	D5	D4	D3	D2	D1	D0
80/81h	Read	Postcode							
	Write	Postcode							
	Reset	00h							

**Postcodes** Postcodes are captured in this register as they are written. Be careful postcodes are not always 16-bit. The high byte in register 81h could be unrelated to the content of register 80h. Also, the legacy floppy disk controller (if any) **MUST** be disabled. The LPC bridge in this design does a full decode and cycle acknowledge on I/O 81h and this will conflict with any other resources that decodes this address.

## B.2.3 A00h: Version

Address	Action	D7	D6	D5	D4	D3	D2	D1	D0	
A00h	Read	Customer			MajorVersion					
	Write	NU			NU					
	Reset	NA			NA					

**Customer** Customer identification.

000: generic Kontron board

001: customer #1 (additional customer-only registers are present)

others: reserved

**MajorVersion** FPGA major version. For the production test software to verify that the latest code was used in the JTAG programming phase (i.e. trap production mistakes). See also LPC-A04h for minor version.

## B.2.4 A01h: Debug LED & Mfg flag

Address	Action	D7	D6	D5	D4	D3	D2	D1	D0
A01h	Read	MfgFlag	0	0	0	0	0	0	0
	Write	MfgFlag	NU	NU	NU	NU	NU	NU	NU
	Reset	0/NA	NA	NA	NA	NA	NA	NA	NA

**MfgFlag** A memory element used by the BIOS and test software in manufacturing.



### Note:

This bit is cleared on a power-up but is not affected by a reset.



### Note:

Unused bits are reserved for alternate LED functionality.

## B.2.5 A02h: FWUM

Address	Action	D7	D6	D5	D4	D3	D2	D1	D0
A02h	Read	NU	RTM	Status	DoProg	RollBack	UART	MODE	RESET
	Write	NU	RTM	NU	DoProg	RollBack	UART	MODE	RESET
	Reset	NU	0	NU	0	0	0	1	0/1

RESET	FWUM reset. The power-up state of this bit will be 0 under normal operating conditions. When the T2604 is present with its jumper inserted or a jumper is inserted between pin #1 and #2 of the T2604 connector, the power-up state will be '1' (FWUM and IPMC in reset). Alternately, the jumper identified as "IPMI Override" has the same effect as the T2604 jumper. Note that this bit is not affected by a reset other than a power up.
MODE	FWUM mode pin.
UART	Set this bit to connect UART1 to the internal FWUM for programming.  Deassert to connect UART1 to the RTM FWUM for programming.
RollBack	Set to 1 for manual rollback (in conjunction with DoProg)  Leave to 0 for normal operation
DoProg	Set to 1 then to 0 to start programming the IPMC with the new code.
Status	1 : FWUM Ready  0 : FWUM Busy
RTM	Asserting this bit will assert signal RTM_RESET in the RTM connector. Depending on the type of RTM used, the behavior will be as follow: <ul style="list-style-type: none"> <li>• Non-intelligent RTM: reset payload devices (futura : RTM ignore this signal).</li> <li>• Intelligent RTM: Put the FWUM on the RTM in firmware upgrade mode.</li> </ul> Use this bit only for firmware update and leave it to '0' otherwise.



### Note:

When RTM='1', the ICH second serial port will automatically be connected to the RTM.

## B.2.6 A03h: BIOS to IPMC Mailbox

Address	Action	D7	D6	D5	D4	D3	D2	D1	D0
A03h	Read	MI7	MI6	MI5	MI4	MI3	MI2	MI1	MI0
	Write	MI7	MI6	MI5	MI4	MI3	MI2	MI1	MI0
	Reset*	0	0	0	0	0	0	0	0

\* Blade insertion only. No reset after that.

MI[0..7] Message from BIOS to IPMC. The state written here is copied to a register in the IPMC address space. Readback by the BIOS is a local readback. The IPMC can clear any of those bits by writing a 1 the corresponding IPMC register. Definition of those bits is entirely left to the software. Definitions may be copied here for convenience.

## B.2.7 A04h: Development Features

Address	Action	D7	D6	D5	D4	D3	D2	D1	D0
A04h	Read	MinorVersion				NU	NU	SSC1	SSC0
	Write	NU	NU	NU	NU	NU	NU	SSC1	SSC0
	Reset	NU	NU	NU	NU	NU	NU	1	1

MinorVersion Minor version that doesn't impact the IPMC. For in-house minor version tracking.

SSC0 Special Serial Connection bit 0

SSC1 Special Serial Connection bit 1

Those bits define special connections between serial devices that are meaningless to the end user. They are development and/or manufacturing facilities. Leave those bits in their default state for end-user operation.

SSC[1:0]	Effect
11	Normal operation (no development tricks).
01	Float FW_RXD pin. Use this to program the FWUM with the POD.
10	Connect FW_RXD and FW_TXD to RJ45 RS232 port
00	Connect B1 (IPMC uart 1) to ICH UART1

## B.2.8 A05h: LEDs Configuration & RTM Test

Address	Action	D7	D6	D5	D4	D3	D2	D1	D0
A05h	Read	RtmTest	0	0	0	0	0	0	0
	Write	RtmTest	NU	NU	NU	NU	NU	NU	NU
	Reset	0	NU	NU	NU	NU	NU	NA	NA

**RtmTest** The value written to this bit is transferred to the RTM in the RTM-Link. The value received by the RTM can be read from location A20h when a production RTM is used (T5702). The RTM also returns the bit through the RTM-Link. The value read from this register comes from the RTM-Link.

Testing procedure:

- set bit RtmTest
- wait for the round trip
- read bit RtmTest (must be 1)
- clear bit RtmTest
- wait for the round trip
- read bit RtmTest (must be 0)



### Note:

This register may be redefined to add LED configuration information (MagJack vs SerDes, etc).

## B.2.9 A06h: Jumpers and PCB version

Address	Action	D7	D6	D5	D4	D3	D2	D1	D0
A06h	Read	PROM	JMP2	JMP1	JMP0	PCB3	PCB2	PCB1	PCB0
	Write	NU	NU	NU	NU	NU	NU	NU	NU
	Reset	NU	NU	NU	NU	NU	NU	NU	NU

**PCB[3..0]** PCB Version

**JMP[2..0]** Various jumpers:

JMP2: clear CMOS in flash (for BIOS use)

JMP1: reserved for now

JMP0: reserved for now

**PROM** Indicate which PROM is currently selected for the FPGA (based on selection jumper).

1 = Jumper absent, user PROM selected.

0 = Jumper present, factory PROM selected

## B.2.10 A07h: BOM version

Address	Action	D7	D6	D5	D4	D3	D2	D1	D0
A07h	Read	BOM7	BOM6	BOM5	BOM4	BOM3	BOM2	BOM1	BOM0
	Write	NU	NU	NU	NU	NU	NU	NU	NU
	Reset	NU	NU	NU	NU	NU	NU	NU	NU

BOM[7..0]

BOM Version. Spare bit may be redefined for other use.

BOM								Option
7	6	5	4	3	2	1	0	
X	X	X	X	X	X	X	1	Flash Drive presence.
X	X	X	X	X	X	1	X	Management LAN presence
X	X	X	X	X	1	X	X	Reserved
X	X	X	X	1	X	X	X	FML Interface used
X	X	X	0	X	X	X	X	Reserved
X	X	0	X	X	X	X	X	Reserved
X	0	X	X	X	X	X	X	Reserved
0	X	X	X	X	X	X	X	Reserved



### Note:

The FPGA/IPMC must adapt to the fact that there is no -5V rail.



### Note:

The telecom clock functionality has an entire byte to specify the configuration or absence (return FF) of the circuit

## B.2.11 A08h: T2604 Mezzanine Flash & BIOS EEPROM Control

Address	Action	D7	D6	D5	D4	D3	D2	D1	D0
A08h	Read	EEWP	NU	NU	NU	NU	ID0	TestMode	HIDE
	Write	EEWP	NU	NU	NU	NU	NU	NU	HIDE
	Reset	1*	NU	NU	NU	NU	NU	N/A	0*

\* not cleared by a reset; power-up only

EEWR

Serial EEPROM write protect. 1 = write protected, 0 = unprotected. An equivalent bit exists in the IPMC address space. The EEPROM is not protected if either the BIOS or the IPMC wants to access it.

ID0	Indicate the current state of FWHs ID0 input. When '1', a T2604 is present and is the active FWH. When cleared (will always be cleared when HIDE='1'), indicate that an onboard FWH is active.
HIDE	Hide T2604 flash. When this bit is cleared, the LPC Flash on the T2604 has an ID0 of 0 and the flashes on the SBC will be forced to different addresses. When this bit is set, the T2604 flash will be at a higher ID. From the SBC main CPU point of view, this is almost like removing the T2604. This bit will be typically used to program its on-board flash for the first time.
TestMode	When set, indicate that the alternate setup default (manufacturing configuration) must be used by the BIOS. This bit reflects the presence of the jumper on the T2604.

## B.2.12 A09h: RTM PLD Version

Address	Action	D7	D6	D5	D4	D3	D2	D1	D0
A09h	Read	NU	NU	NU	VALID	RPLD3	RPLD2	RPLD1	RPLD0
	Write	NU	NU	NU	NU	NU	NU	NU	NU
	Reset	NU	NU	NU	NU	NU	NU	NU	NU

Valid When set, indicate that field RPLD is valid.

RPLD[3..0] PLD Version

## B.2.13 A0Ah: Reset History

Address	Action	D7	D6	D5	D4	D3	D2	D1	D0
A0Ah	Read	0	0	0	0	LastReset			
	Write	NU	NU	NU	NU	NU	NU	NU	NU
	Reset	NU	NU	NU	NU	NU	NU	NU	NU

LastReset This value indicates the last reset that happened. In case of multiple back-to-back resets, only the last one is reported here. Interpretation is as follow:

0000: Reserved

0001: Power up

0010: Reserved (Initial WD)

0011: Reserved (Prog wd cold)

0100: Reserved (Prog wd warm)

0101: Software initiated cold reset (ICH's CF9h write)

0110: Software initiated warm reset (ICH's CF9h write)

0111: Cold reset initiated by IPMC

1000: Warm reset initiated by IPMC

1001: Warm reset initiated by front panel pushbutton

Others: reserved

## B.2.14 AOBh: Mezzanine Identification

Address	Action	D7	D6	D5	D4	D3	D2	D1	D0
A0Ch	Read	0	0	LoopIn	MezzPr	MezzID3	MezzID2	MezzID1	MezzID0
	Write	NU	NU	LoopOut	NU	NU	NU	NU	NU
	PowerUp	NU	NU	0	NU	NU	NU	NU	NU

**MezzPr** Indicate that the PCI-Express mezzanine (daughter card, piggy back, storage mezzanine) is present. If not present, MezzID is not valid (see below). Note that this bit will not switch to 1 immediately on a power up. The FPGA has to read the mezzanine identification through a shift register. As soon as the ID has been read, the presence bit is asserted

**MezzID** Mezzanine ID. Indicate the type of mezzanine that is present. If MezzPr=0, this field is meaningless. Currently supported mezzanines are listed in the table below. Note that the FPGA reads the mezzanine information continuously but some delay is required immediately at power up. The IPMI subsystem is left in reset as long as the status of the mezzanine is unknowned.

MezzPr	MezzID	Description
0	XXXX	No mezzanine board.
1	1111	SATA Bypass mezzanine. Fully passive. The FPGA does nothing special for this one.
1	0001	T5511, SAS-only mezzanine. The FPGA will sequence the power supplies and grab various statuses from the mezzanine.
1	0010	FC mezzanine. The FPGA will sequence the power supplies and grab various statuses from the mezzanine.
1	0100	T5511, 1000Base-BX only mezzanine. The FPGA will sequence the power supplies and grab various statuses from the mezzanine.
1	0101	T5511, SAS & 1000Base-BX mezzanine. The FPGA will sequence the power supplies and grab various statuses from the mezzanine.
1	Others	Reserved for now.

Removal of the mezzanine while the power is ON is an illegal operation.

## B.2.15 A0C-A0Fh: Telcom Clock Interface

Please refer to section B3 for more details on the actual configuration used.

## B.2.16 378-37Ah: Xilinx DLC5 JTAG Programmer Emulator

### B.2.16.1 378h: LPT data register

Address	Action	D7	D6	D5	D4	D3	D2	D1	D0
378h	Read	LD7	LD6	LD5	LD4	LD3	LD2	LD1	LD0
	Write	LD7	LD6	LD5	LD4	LD3	LD2	LD1	LD0
	Reset	0	0	0	0	0	0	0	0

LD[7..0] LPT data write and readback. Only a subset of those pins has a physical implementation.

### B.2.16.2 379h: LPT status register

Address	Action	D7	D6	D5	D4	D3	D2	D1	D0
379h	Read	BUSY#	ACK#	PE	SLCTI	ERR	IRQ#	0	0
	Write	NU	NU	NU	NU	NU	NU	NU	NU
	Reset	NU	NU	NU	NU	NU	NU	NU	NU

BUSY# Printer busy.  
ACK# Printer acknowledge. Always return 1 (no ack).  
PE Printer out of paper (paper empty).  
SLCTI Select in.  
ERR Error.  
IRQ# Interrupt status. Always return 1 (no interrupt).

### B.2.16.3 37Ah: LPT control register

Address	Action	D7	D6	D5	D4	D3	D2	D1	D0
37Ah	Read	0	0	0	0	Slct0#	INIT	ALF#	STRB#
	Write	NU	NU	NU	NU	Slct0#	INIT	ALF#	STRB#
	Reset	NU	NU	NU	NU	1	1	1	1

SLCTO# Printer Select Output.  
INIT Reset printer. 0=reset, 1=normal.  
ALF# Auto Line Feed.  
STRB# Strobe.

# C. Connector Pinouts

## C.1 Connectors and Headers Summary

Connector	Description
J7	RTM Connector
J13	USB 2.0 Connector
J14	Serial Port Connector
J17	Telco Clock Connector & Fabric Interface
J20	AMC B1
J21	Base Interface Connector
J23	AMC B2
P1	Power Connector

## C.2 ATCA I/O RTM Connector (J7)

Pin	ROW A	ROW B	ROW C	ROW D	ROW E	ROW F
1	V_12V_1	V_12V_5	V_12V_2	V_3V2_SUS	RTM_EJECT	RTM_PRSENT#
2	V_12V_3	V_12V_6	V_12V_4	IPMC_INT#	IPMC_SCL	IPMC_SDA
3	SP_TX	SP_RX	SP_DTR	SP_RTS	SP_CTS	SP_DSR
4	Reserved	Reserved	Reserved	Reserved	RTML_TX	RTML_RX
5	N.C.	N.C.	N.C.	N.C.	N.C.	N.C.
6	N.C.	N.C.	N.C.	N.C.	N.C.	N.C.
7	N.C.	N.C.	N.C.	N.C.	N.C.	N.C.
8	N.C.	N.C.	N.C.	N.C.	N.C.	N.C.
9	P0_TX+	P0_TX-	P0_RX-	P1_TX+	P1_TX-	P1_TX-
10	P2_TX+	P2_TX-	P2_RX+	P2_RX-	P3_TX+	P3_TX-

Pin	ROW G	ROW H	ROW AB	ROW CD	ROW EF	ROW GH
1	RTM_HS_LED	RTM_EN#	GND	GND	GND	GND
2	USB1_D+R	USB1_D-R	GND	GND	GND	GND
3	N.C.	N.C.	GND	GND	GND	GND
4	RTML_CLK	N.C.	GND	GND	GND	GND
5	N.C.	N.C.	GND	GND	GND	GND
6	N.C.	N.C.	GND	GND	GND	GND
7	N.C.	N.C.	GND	GND	GND	GND
8	N.C.	N.C.	GND	GND	GND	GND
9	P1_RX+	P1_RX-	GND	GND	GND	GND
10	P3_RX+	P3_RX-	GND	GND	GND	GND

## C.3 USB Port (J13)

Signal	Pin
VCC	1
DATA-	2
DATA+	3
GND	4

## C.4 Serial Port(J14)

Signal	Pin	Pin	Signal
RTS	1	5	GND
DTR	2	6	RX#
TX#	3	7	DSR
GND/DCD	4	8	CTS

## C.5 Telco Clock(J17)

Pin	ROW A	ROW B	ROW C	ROW D	ROW E	ROW F
1	CLK1A+	CLK1A-	CLK1B+	CLK1B-	CLK2A+	CLK2A-
2	Tx4(UP)+	Tx4(UP)-	Rx4(UP)+	Rx4(UP)-	CLK3A+	CLK3A-
3	Tx2(UP)+	Tx2(UP)-	Rx2(UP)+	Rx2(UP)-	Tx3(UP)+	Tx3(UP)-
4	Tx0(UP)+	Tx0(UP)-	Rx0(UP)+	Rx0(UP)-	Tx1(UP)+	Tx1(UP)-
5	Tx2[15]+(N.C.)	Tx2[15]-(N.C.)	Rx2[15]+(N.C.)	Rx2[15]-(N.C.)	Tx3[15]+(N.C.)	Tx3[15]-(N.C.)
6	Tx0[15]+(N.C.)	Tx0[15]-(N.C.)	Rx0[15]+(N.C.)	Rx0[15]-(N.C.)	Tx1[15]+(N.C.)	Tx1[15]-(N.C.)
7	Tx2[14]+(N.C.)	Tx2[14]-(N.C.)	Rx2[14]+(N.C.)	Rx2[14]-(N.C.)	Tx3[14]+(N.C.)	Tx3[14]-(N.C.)
8	Tx0[14]+(N.C.)	Tx0[14]-(N.C.)	Rx0[14]+(N.C.)	Rx0[14]-(N.C.)	Tx1[14]+(N.C.)	Tx1[14]-(N.C.)
9	Tx2[13]+(N.C.)	Tx2[13]-(N.C.)	Rx2[13]+(N.C.)	Rx2[13]-(N.C.)	Tx3[13]+(N.C.)	Tx3[13]-(N.C.)
10	Tx0[13]+(N.C.)	Tx0[13]-(N.C.)	Rx0[13]+(N.C.)	Rx0[13]-(N.C.)	Tx1[13]+(N.C.)	Tx1[13]-(N.C.)

Pin	ROW G	ROW H	ROW AB	ROW CD	ROW EF	ROW GH
1	CLK2B+	CLK2B-	GND	GND	GND	GND
2	CLK3B+	CLK3B-	GND	GND	GND	GND
3	Rx3(UP)+	Rx3(UP)-	GND	GND	GND	GND
4	Rx1(UP)+	Rx1(UP)-	GND	GND	GND	GND
5	Rx3[15]+(N.C.)	Rx3[15]-(N.C.)	GND	GND	GND	GND
6	Rx1[15]+(N.C.)	Rx1[15]-(N.C.)	GND	GND	GND	GND
7	Rx3[14]+(N.C.)	Rx3[14]-(N.C.)	GND	GND	GND	GND
8	Rx1[14]+(N.C.)	Rx1[14]-(N.C.)	GND	GND	GND	GND
9	Rx3[13]+(N.C.)	Rx3[13]-(N.C.)	GND	GND	GND	GND
10	Rx1[13]+(N.C.)	Rx1[13]-(N.C.)	GND	GND	GND	GND

## C.6 AMC B1 & AMC B2 (J20 & J23)

Pin	Signal	Pin	Signal	Pin	Signal	Pin	Signal
B1	GND	B43	GND	B86	GND	B129	TxD15-
B2	12V	B44	RxD4+	B87	TxD8-	B130	TxD15+
B3	PS1#	B45	RxD4-	B88	TxD8+	B131	GND
B4	MP_3V3	B46	GND	B89	GND	B132	RxD15-
B5	GA0	B47	TxD4+	B90	RxD8-	B133	RxD15+
B6	RSV	B48	TxD4-	B91	RxD8+	B134	GND
B7	GND	B49	GND	B92	GND	B135	TCLKC+
B8	RSV	B50	RxD5+	B93	TxD9-	B136	TCLKC-
B9	12V	B51	RxD5-	B94	TxD9+	B137	GND
B10	GND	B52	GND	B95	GND	B138	TCLKD+
B11	RxD0+	B53	TxD5+	B96	RxD9-	B139	TCLKD-
B12	RxD0-	B54	TxD5-	B97	RxD9+	B140	GND
B13	GND	B55	GND	B98	GND	B141	TxD17-
B14	TxD0+	B56	IPMB-L-SCL	B99	TxD10-	B142	TxD17+
B15	TxD0-	B57	12V	B100	TxD10+	B143	GND
B16	GND	B58	GND	B101	GND	B144	RxD17-
B17	GA1	B59	RxD6+	B102	RxD10-	B145	RxD17+
B18	12V	B60	RxD6-	B103	RxD10+	B146	GND
B19	GND	B61	GND	B104	GND	B147	TxD18-
B20	RxD1+	B62	TxD6+	B105	TxD11-	B148	TxD18+
B21	RxD1-	B63	TxD6-	B106	TxD11+	B149	GND
B22	GND	B64	GND	B107	GND	B150	RxD18-
B23	TxD1+	B65	RxD7+	B108	RxD11-	B151	RxD18+
B24	TxD1-	B66	RxD7-	B109	RxD11+	B152	GND
B25	GND	B67	GND	B110	GND	B153	TxD19-
B26	GA2	B68	TxD7+	B111	TxD12-	B154	TxD19+
B27	12V	B69	TxD7-	B112	TxD12+	B155	GND
B28	GND	B70	GND	B113	GND	B156	RxD19-
B29	RxD2+	B71	IPMB_SDA	B114	RxD12-	B157	RxD19+
B30	RxD2-	B72	12V	B115	RxD12+	B158	GND
B31	GND	B73	GND	B116	GND	B159	TxD20-
B32	TxD2+	B74	TCLKA+	B117	TxD13-	B160	TxD20+
B33	TxD2-	B75	TCLKA-	B118	TxD13+	B161	GND
B34	GND	B76	GND	B119	GND	B162	RxD20-
B35	RxD3+	B77	TCLKB+	B120	RxD13-	B163	RxD20+
B36	RxD3-	B78	TCLKB-	B121	RxD13+	B164	GND
B37	GND	B79	GND	B122	GND	B165	TCLK
B38	TxD3+	B80	FCLKA+	B123	TxD14-	B166	TMS
B39	TxD3-	B81	FCLKA-	B124	TxD14+	B167	TRST#

Pin	Signal	Pin	Signal	Pin	Signal	Pin	Signal
B40	GND	B82	GND	B125	GND	B168	TDO
B41	ENABLE#	B83	PS0#(GND)	B126	RxD14-	B169	TDI
B42	12V	B84	12V	B127	RxD14+	B170	GND
		B85	GND	B128	GND		

## C.7 ATCA I/O ATCA 3.1 (J21)

Pin	ROW A	ROW B	ROW C	ROW D	ROW E	ROW F
1	Tx2[2]+	Tx2[2]-	Rx2[2]+	Rx2[2]-	Tx3[2]+	Tx3[2]-
2	Tx0[2]+	Tx0[2]-	Rx0[2]+	Rx0[2]-	Tx1[2]+	Tx1[2]-
3	Tx2[1]+	Tx2[1]-	Rx2[1]+	Rx2[1]-	Tx3[1]+	Tx3[1]-
4	Tx0[1]+	Tx0[1]-	Rx0[1]+	Rx0[1]-	Tx1[1]+	Tx1[1]-
5	BI_DA1+	BI_DA1-	BI_DB1+	BI_DB1-	BI_DC1+	BI_DC1-
6	BI_DA2+	DI_DA2-	BI_DB2+	BI_DB2-	DI_DC2+	BI_DC2-
7	N.C.	N.C.	N.C.	N.C.	N.C.	N.C.
8	N.C.	N.C.	N.C.	N.C.	N.C.	N.C.
9	N.C.	N.C.	N.C.	N.C.	N.C.	N.C.
10	N.C.	N.C.	N.C.	N.C.	N.C.	N.C.

Pin	ROW G	ROW H	ROW AB	ROW CD	ROW EF	ROW GH
1	Rx3[2]+	Rx3[2]-	GND	GND	GND	GND
2	Rx1[2]+	Rx1[2]-	GND	GND	GND	GND
3	Rx3[1]+	Rx3[1]-	GND	GND	GND	GND
4	Rx1[1]+	Rx1[1]-	GND	GND	GND	GND
5	BI_DD1+	BI_DD1-	GND	GND	GND	GND
6	BI_DD2+	DI_DD2-	GND	GND	GND	GND
7	N.C.	N.C.	GND	GND	GND	GND
8	N.C.	N.C.	GND	GND	GND	GND
9	N.C.	N.C.	GND	GND	GND	GND
10	N.C.	N.C.	GND	GND	GND	GND

## C.8 Power (P10)

Signal	Pin	Pin	Signal
N.P.	1	2	N.P.
N.P.	3	4	N.P.
HA0	5	6	HA1
HA2	7	8	HA3
HA4	9	10	HA5
HA6	11	12	HA7/P
IPMBA_SCL	13	14	SDA_A
SCL_B	15	16	SDA_B
N.C.	17	18	N.C.
N.C.	19	20	N.C.
N.C.	21	22	N.C.
N.C.	23	24	N.C.
SHELF_GND	25	26	LOGIC_GND
ENABLE_B	27	28	VRTN_A
VRTN_B	29	30	EARLY_A
EARLY_B	31	32	ENABLE_A
-48V_A	33	34	-48V_B

# D. BIOS Setup Error Codes

## D.1 Bootblock Initialization Code Checkpoints

The Bootblock initialization code sets up the chipset, memory and other components before system memory is available. The following table describes the type of checkpoints that may occur during the bootblock initialization portion of the BIOS:

Checkpoint	Description
Before D1	Early chipset initialization is done. Early super I/O initialization is done including RTC and keyboard controller. NMI is disabled.
D1	Perform keyboard controller BAT test. Check if waking up from power management suspend state. Save power-on CPUID value in scratch CMOS.
D0	Go to flat mode with 4GB limit and GA20 enabled. Verify the bootblock checksum.
D2	Disable CACHE before memory detection. Execute full memory sizing module. Verify that flat mode is enabled.
D3	If memory sizing module not executed, start memory refresh and do memory sizing in Bootblock code. Do additional chipset initialization. Re-enable CACHE. Verify that flat mode is enabled.
D4	Test base 512KB memory. Adjust policies and cache first 8MB. Set stack.
D5	Bootblock code is copied from ROM to lower system memory and control is given to it. BIOS now executes out of RAM.
D6	Both key sequence and OEM specific method is checked to determine if BIOS recovery is forced. Main BIOS checksum is tested. If BIOS recovery is necessary, control flows to checkpoint E0. See Bootblock Recovery Code Checkpoints section of document for more information.
D7	Restore CPUID value back into register. The Bootblock-Runtime interface module is moved to system memory and control is given to it. Determine whether to execute serial flash.
D8	The Runtime module is uncompressed into memory. CPUID information is stored in memory.
D9	Store the Uncompressed pointer for future use in PMM. Copying Main BIOS into memory. Leaves all RAM below 1MB Read-Write including E000 and F000 shadow areas but closing SMRAM.
DA	Restore CPUID value back into register. Give control to BIOS POST (ExecutePOSTKernel). See POST Code Checkpoints section of document for more information.
E1-E8	
EC-EE	OEM memory detection/configuration error. This range is reserved for chipset vendors & system manufacturers. The error associated with this value may be different from one platform to the next. Refer to memory initialization ERROR CODE D.5

## D.2 Bootblock Recovery Code Checkpoints

The Bootblock recovery code gets control when the BIOS determines that a BIOS recovery needs to occur because the user has forced the update or the BIOS checksum is corrupt. The following table describes the type of checkpoints that may occur during the Bootblock recovery portion of the BIOS

Checkpoint	Description
E0	Initialize the floppy controller in the super I/O (if present). Some interrupt vectors are initialized. DMA controller is initialized. 8259 interrupt controller is initialized. L1 cache is enabled.
E9	Set up floppy controller and data. Attempt to read from media.
EA	Enable ATAPI hardware. Attempt to read from ARMD and ATAPI CDROM.
EB	Disable ATAPI hardware. Jump back to checkpoint E9.
EF	Read error occurred on media. Jump back to checkpoint EB.
F0	Search for pre-defined recovery file name in root directory.
F1	Recovery file not found.
F2	Start reading FAT table and analyze FAT to find the clusters occupied by the recovery file.
F3	Start reading the recovery file cluster by cluster.
FA	Validate the recovery file configuration with the current configuration of the flash
FB	Enable flash write through chipset and OEM specific method. Detect proper flash part. Verify that the found flash part is the same size than the recovery file.
F4	The recovery file size does not equal the found flash part size.
FC	Erase the flash part.
FD	Program the flash part.
FF	The flash has been updated successfully. Make flash write disabled. Disable ATAPI hardware. Restore CPUID value back into register. Give control to F000 ROM at F000:FFF0h.

## D.3 POST Code Checkpoints

The POST code checkpoints are the largest set of checkpoints during the BIOS pre-boot process. The following table describes the type of checkpoints that may occur during the POST portion of the BIOS:

Checkpoint	Description
03	Disable NMI, Parity, video for EGA, and DMA controllers. Initialize BIOS, POST, Runtime data area. Also initialize BIOS modules on POST entry and GPNV area. Initialize CMOS as mentioned in the Kernel Variable "wCMOSFlags."
04	Check CMOS diagnostic byte to determine if battery power is OK and CMOS checksum is OK. Verify CMOS checksum manually by reading storage area. If the CMOS checksum is bad, update CMOS with power-on default values and clear passwords. Initialize status register A. Initializes data variables that are based on CMOS setup questions. Initializes both the 8259 compatible PICs in the system
05	Initializes the interrupt controlling hardware (generally PIC) and interrupt vector table.
06	Do R/W test to CH-2 count reg. Initialize CH-0 as system timer. Install the POSTINT1Ch handler. Enable IRQ-0 in PIC for system timer interrupt. Traps INT1Ch vector to "POSTINT1ChHandlerBlock."

Checkpoint	Description
08	Initializes the CPU. The BAT test is being done on KBC. Program the keyboard controller command byte is being done after Auto detection of KB/MS using AMI KB-5.
C0	Early CPU Init Start -- Disable Cache - Init Local APIC
C1	Set up boot strap processor Information
C2	Set up boot strap processor for POST
C5	Enumerate and set up application processors
C6	Re-enable cache for boot strap processor
C7	Early CPU Init Exit
0A	Initializes the 8042 compatible Key Board Controller.
0B	Detects the presence of PS/2 mouse.
0C	Detects the presence of Keyboard in KBC port.
0E	Testing and initialization of different Input Devices. Also, update the Kernel Variables. Traps the INT09h vector, so that the POST INT09h handler gets control for IRQ1. Uncompress all available language, BIOS logo, and Silent logo modules.
13	Early POST initialization of chipset registers.
24	Uncompress and initialize any platform specific BIOS modules.
30	Initialize System Management Interrupt.
2A	Initializes different devices through DIM. See DIM Code Checkpoints section of document for more information.
2C	Initializes different devices. Detects and initializes the video adapter installed in the system that have optional ROMs.
2E	Initializes all the output devices.
31	Allocate memory for ADM module and uncompress it. Give control to ADM module for initialization. Initialize language and font modules for ADM. Activate ADM module.
33	Initializes the silent boot module. Set the window for displaying text information.
37	Displaying sign-on message, CPU information, setup key message, and any OEM specific information.
38	Initializes different devices through DIM. See DIM Code Checkpoints section of document for more information.
39	Initializes DMAC-1 & DMAC-2.
3A	Initialize RTC date/time.
3B	Test for total memory installed in the system. Also, Check for DEL or ESC keys to limit memory test. Display total memory in the system.
3C	Mid POST initialization of chipset registers.
40	Detect different devices (Parallel ports, serial ports, and coprocessor in CPU, ... etc.) successfully installed in the system and update the BDA, EBDA...etc.
50	Programming the memory hole or any kind of implementation that needs an adjustment in system RAM size if needed.
52	Updates CMOS memory size from memory found in memory test. Allocates memory for Extended BIOS Data Area from base memory.
60	Initializes NUM-LOCK status and programs the KBD typematic rate.
75	Initialize Int-13 and prepare for IPL detection.
78	Initializes IPL devices controlled by BIOS and option ROMs.
7A	Initializes remaining option ROMs.
7C	Generate and write contents of ESCD in NVRam.

Checkpoint	Description
84	Log errors encountered during POST.
85	Display errors to the user and gets the user response for error.
87	Execute BIOS setup if needed / requested.
8C	Late POST initialization of chipset registers.
8D	Build ACPI tables (if ACPI is supported)
8E	Program the peripheral parameters. Enable/Disable NMI as selected
90	Late POST initialization of system management interrupt.
A0	Check boot password if installed.
A1	Clean-up work needed before booting to OS.
A2	Takes care of runtime image preparation for different BIOS modules. Fill the free area in F000h segment with 0FFh. Initializes the Microsoft IRQ Routing Table. Prepares the runtime language module. Disables the system configuration display if needed.
A4	Initialize runtime language module.
A7	Displays the system configuration screen if enabled. Initialize the CPU's before boot, which includes the programming of the MTRR's.
A8	Prepare CPU for OS boot including final MTRR values.
A9	Wait for user input at config display if needed.
AA	Uninstall POST INT1Ch vector and INT09h vector. Deinitializes the ADM module.
AB	Prepare BBS for Int 19 boot.
AC	End of POST initialization of chipset registers.
B1	Save system context for ACPI.
00	Passes control to OS Loader (typically INT19h).
61-70	OEM POST Error. This range is reserved for chipset vendors & system manufacturers. The error associated with this value may be different from one platform to the next.
DD-DE	OEM PCI init debug POST code during DIMM init, See DIM Code Checkpoints section of document for more information.

## D.4 DIM Code Checkpoints

The Device Initialization Manager (DIM) gets control at various times during BIOS POST to initialize different system busses. The following table describes the main checkpoints where the DIM module is accessed:

Checkpoint	Description
2A	Initialize different buses and perform the following functions: Reset, Detect, and Disable (function 0); Static Device Initialization (function 1); Boot Output Device Initialization (function 2). Function 0 disables all device nodes, PCI devices, and PnP ISA cards. It also assigns PCI bus numbers. Function 1 initializes all static devices that include manual configured onboard peripherals, memory and I/O decode windows in PCI-PCI bridges, and noncompliant PCI devices. Static resources are also reserved. Function 2 searches for and initializes any PnP, PCI, or AGP video devices.
38	Initialize different buses and perform the following functions: Boot Input Device Initialization (function 3); IPL Device Initialization (function 4); General Device Initialization (function 5). Function 3 searches for and configures PCI input devices and detects if system has standard keyboard controller. Function 4 searches for and configures all PnP and PCI boot devices. Function 5 CONFIGURES all onboard peripherals that are set to an automatic configuration and configures all remaining PnP and PCI devices.
DD-DE	OEM PCI init debug POST code during DIMM init. DEh during BUS number assignment and DDh during ressource allocation, Hight byte is the BUS number.

While control is in the different functions, additional checkpoints are output to port 80h as a word value to identify the routines under execution. The low byte value indicates the main POST Code Checkpoint. The high byte is divided into two nibbles and contains two fields. The details of the high byte of these checkpoints are as follows:

### HIGH BYTE XY

The upper nibble 'X' indicates the function number that is being executed. 'X' can be from 0 to 7.

0 = func#0, disable all devices on the BUS concerned.

1 = func#1, static devices initialization on the BUS concerned.

2 = func#2, output device initialization on the BUS concerned.

3 = func#3, input device initialization on the BUS concerned.

4 = func#4, IPL device initialization on the BUS concerned.

5 = func#5, general device initialization on the BUS concerned.

6 = func#6, error reporting for the BUS concerned.

7 = func#7, add-on ROM initialization for all BUSes.

8 = func#8, BBS ROM initialization for all BUSes.

The lower nibble 'Y' indicates the BUS on which the different routines are being executed. 'Y' can be from 0 to 5.

0 = Generic DIM (Device Initialization Manager).

1 = On-board System devices.

2 = ISA devices.

3 = EISA devices.

4 = ISA PnP devices.

5 = PCI devices.

## D.5 ACPI Runtime Checkpoints

ACPI checkpoints are displayed when an ACPI capable operating system either enters or leaves a sleep state. The following table describes the type of checkpoints that may occur during ACPI sleep or wake events:

Checkpoint	Description
AC	First ASL check point. Indicates the system is running in ACPI mode.
AA	System is running in APIC mode.
01, 02, 03, 04, 05	Entering sleep state S1, S2, S3, S4, or S5.
10, 20, 30, 40, 50	Waking from sleep state S1, S2, S3, S4, or S5.

## D.6 Memory Initialization ERROR Code

Checkpoint	Description
E1h	Memory Error - No memory installed.
E2h	Memory Error - Memory type mismatch.
E3h	Memory Error - Unsupported DIMM type.
E4h	Memory Error - Channel mismatch.
EAh	Memory Error - Memory timing error
EEh	Memory Error - Memory unsupported size.
EFh	Memory Error - Memory population order.
F1h	Memory Error - DIMM configuration error.
F3h	Memory Error - Error code for unsuccessful Memory Test.
F4h	Memory Error - Error code for unsuccessful ECC and Memory Initialization
F5h	Memory Error - Receive enable is busted so halt here

# E. Software Update

## E.1 Flash BIOS Update Procedure

The Flash BIOS update procedure is detailed in a ReadMe file included with the Flash BIOS package as well as the update utility. This package can be downloaded from our website [www.kontron.com](http://www.kontron.com) or from our FTP site <ftp://ftp.kontron.ca/Support>

## E.2 IPMC Firmware Update Procedure

The IPMC Firmware update procedure is detailed in a ReadMe file included with the IPMC Firmware package as well as the update utility. This package can be downloaded from our website <http://www.kontron.com> or from our FTP site <ftp://ftp.kontron.ca/Support>

# F. Getting Help

If, at any time, you encounter difficulties with your application or with any of our products, or if you simply need guidance on system setups and capabilities, contact our Technical Support at:

North America

Tel.: (450) 437-5682

Fax: (450) 437-8053

EMEA

Tel.: +49 (0) 8341 803 333

Fax: +49 (0) 8341 803 339

If you have any questions about Kontron, our products, or services, visit our Web site at: [www.kontron.com](http://www.kontron.com)

You also can contact us by E-mail at:

North America: [support@ca.kontron.com](mailto:support@ca.kontron.com)

EMEA: [support-kom@kontron.com](mailto:support-kom@kontron.com)

Or at the following address:

North America

Kontron Canada, Inc.

616 Curé Boivin

Boisbriand, Québec

J7G 2A7 Canada

EMEA

Kontron Modular Computers GmbH

Sudetenstrasse 7

87600 Kaufbeuren

Germany

# F.1 Returning Defective Merchandise

Before returning any merchandise please do one of the following:

- Call
  - 1 Call our Technical Support department in North America at (450) 437-5682 and in EMEA at +49 (0) 8341 803 333. Make sure you have the following on hand: our Invoice #, your Purchase Order #, and the Serial Number of the defective unit.
  - 2 Provide the serial number found on the back of the unit and explain the nature of your problem to a service technician.
  - 3 The technician will instruct you on the return procedure if the problem cannot be solved over the telephone.
  - 4 Make sure you receive an RMA # from our Technical Support before returning any merchandise.
  
- Fax
  - 1 Make a copy of the request form on the following page.
  - 2 Fill it out.
  - 3 Fax it to us at: North America (450) 437-0304, EMEA +49 (0) 8341 803 339
  
- E-mail
  - 1 Send us an e-mail at: [RMA@ca.kontron.com](mailto:RMA@ca.kontron.com) in North America and at: [orderprocessing@kontron-modular.com](mailto:orderprocessing@kontron-modular.com) in EMEA. In the e-mail, you must include your name, your company name, your address, your city, your postal/zip code, your phone number, and your e-mail. You must also include the serial number of the defective product and a description of the problem.

## F.2 When Returning a Unit

- In the box, you must include the name and telephone number of a contact person, in case further explanations are required. Where applicable, always include all duty papers and invoice(s) associated with the item(s) in question.
- Ensure that the unit is properly packed. Pack it in a rigid cardboard box.
- Clearly write or mark the RMA number on the outside of the package you are returning.
- Ship prepaid. We take care of insuring incoming units.

### North America

Kontron Canada, Inc.  
616 Curé Boivin  
Boisbriand, Québec  
J7G 2A7 Canada

### EMEA

Kontron Modular Computers GmbH  
Sudetenstrasse 7  
87600 Kaufbeuren  
Germany



**Return to  
Manufacturer  
Authorization Request**

Contact Name:	_____	
Company Name:	_____	
Street Address:	_____	
City:	_____ Province/State:	_____
Country:	_____ Postal/Zip Code:	_____
Phone Number:	_____ Extension:	_____
Fax Number:	_____ E-Mail:	_____

Serial Number	Failure or Problem Description	P.O. # (if not under warranty)

**Fax this form to Kontron's Technical Support department  
in North America at (450) 437-0304  
in EMEA at +49 (0) 8341 803 339**